

# CUSTOM PROJECTS

lighting design made in Italy



2021

---

**custom selected projects**

## custom projects

Our team works with contemporary designers and architects from all-over the world to plan and develop high-end bespoke projects.

From the initial design concept to the final logistics, our team works alongside our clients at every step to provide tailored lighting solutions for residential settings, offices and co-working spaces, as well as hotels and showrooms.

Andcosta provides continuous support throughout the entire course of a project and our team is always on hand to provide professional and constructive advice.

We can realize great projects together, contact us!

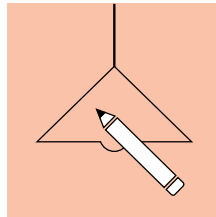

custom lighting solutions

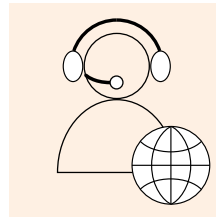

international customer service

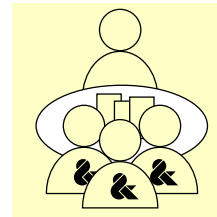

our team's support

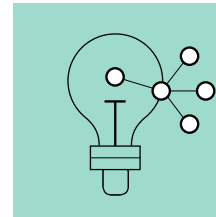

research and technologies



high-quality standard

AndCosta's skills are at your service

## bespoke production



Bespoke Tailoring is a “product customization” service, designed specifically for this kind of creation. In addition to the proposal available in the catalogue, the company offers the possibility of creating lamps tailored to specific needs or to produce modular variants of existing.

## adaptation of catalogue products



We offer to our clients the possibility to customize all AndCosta's products catalogue with personalized finishes and light solutions perfectly designed to response to all the lighting international regulations requirement with the highest performance.

## unique solutions



Each light installation is designed according to the customer's needs and responding to the characteristics decided during the product development phases.



CATEGORY \_\_\_\_\_

**hotel**

# hotel

**lighting solutions  
for five stars hotel  
in Amsterdam**

Born from the observation  
of telephone wires  
and lines of electricity,  
elements that play  
an integral part in the  
building: **brass tubes**  
run on the whole surface  
acting as a distinctive  
element that  
becomes light.

**Amsterdam — 2016**

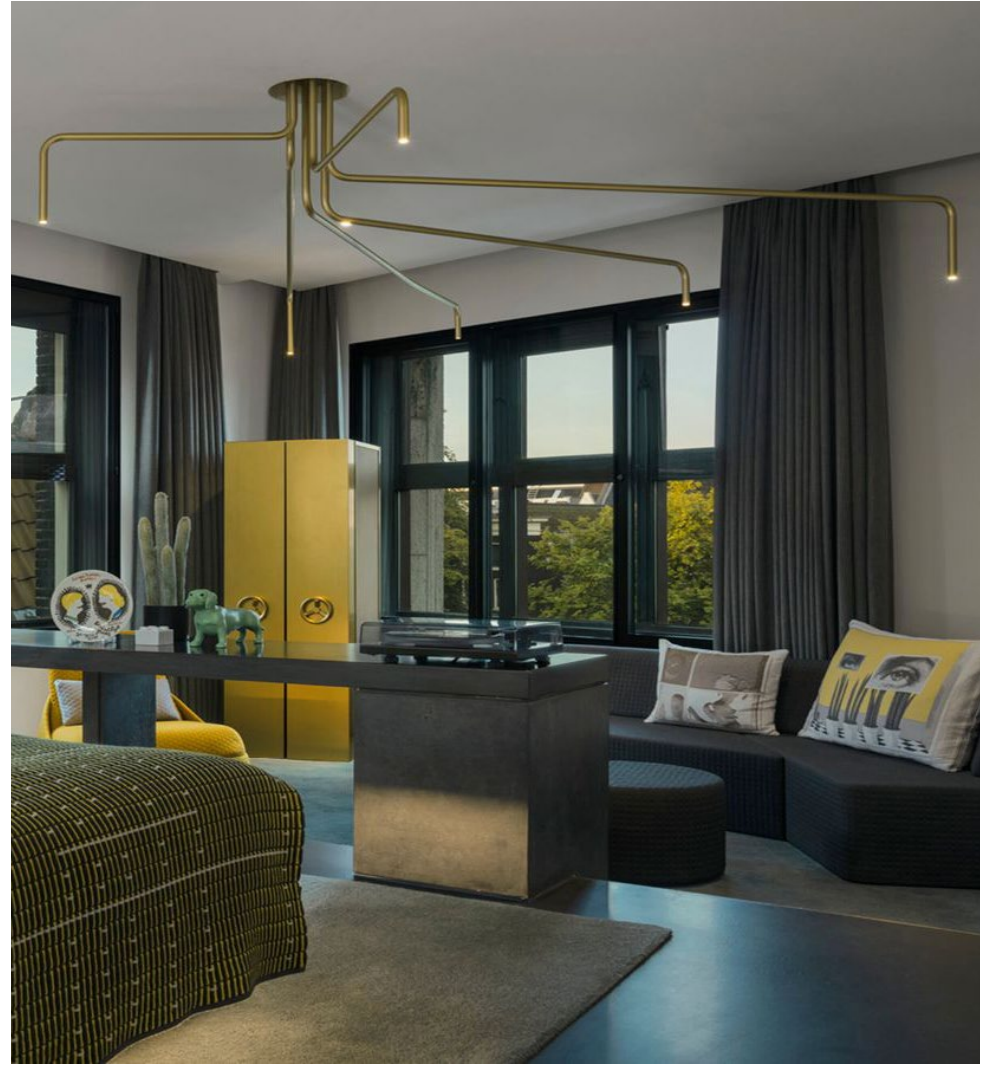











# hotel

**lighting solutions  
for a five stars hotel  
in Tel Aviv**

This magnificent space features recessed stained-glass windows, arched ceilings, and ornate plasterwork details. With a stunning views of the district's old centre and the Mediterranean, and the enchanting landscape, the hotel deliver a 120 luxury rooms, 32 residences, a series of amenities and two signature restaurants.



**Tel Aviv — 2017**









# hotel

**unique lighting solution  
for a five stars hotel  
in Frankfurt**

Mouth blown Murano  
glass tentacles  
that shared a polished  
steel structure.  
The design figuratively  
translated the concept  
of waves through  
a series of curved  
rhythmic lines of  
mouth blown glass.

**Frankfurt — 2016**





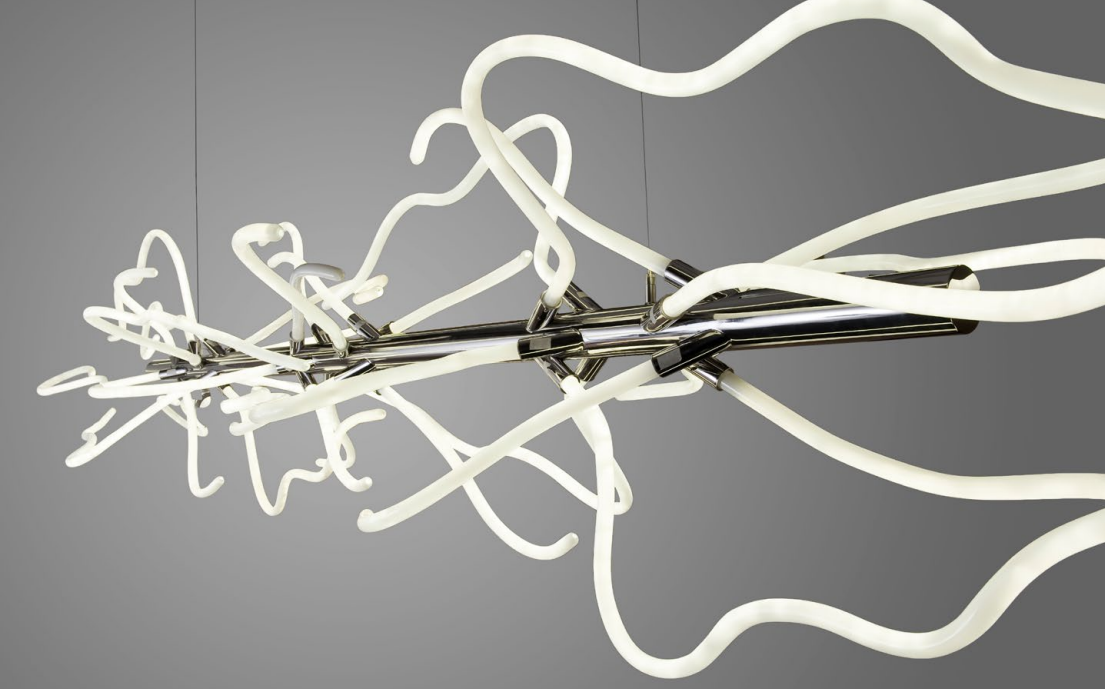

# hotel

**custom tailored lighting for  
the common area of a  
5 stars hotel in Barcelona**

A smooth and nostalgic  
light capable to released  
a warm atmosphere  
for the common areas.

**Barcelona — 2019**











# hotel

**custom lighting solutions  
for the bistrot-restaurant area  
of a hotel in New York**

As a play of surface's  
offsets, this design  
results full-integrated  
with the warm  
environment of the  
Bistrot.

**New York — 2019**







CATEGORY \_\_\_\_\_

**office**

# office

**custom lighting project for the new Headquarters of a fashion brand in München.**

The great attention to psychophysical well-being was the focus of the project which perfectly integrates with the choice of **Luna suspension**, that has a very **low UGR value** to ensure maximum comfort in the workplace **and is flicker free**. The luminous elements are arranged as **floating membranes**, suspensions that create suggestive shades of light **following the natural external lighting**.

**München — 2021**

















# office

**Lighting solutions  
for office and  
sharing spaces  
in Tel Aviv**

The designer has chosen elegant and **soft lines and colors**, light ash wood, finishes in olive and coral, to define the space that works in sync with more linear elements **that can be seen**, for example, in the details of custom-made furniture and ceiling elements **throughout the space.**

**Tel Aviv — 2019**











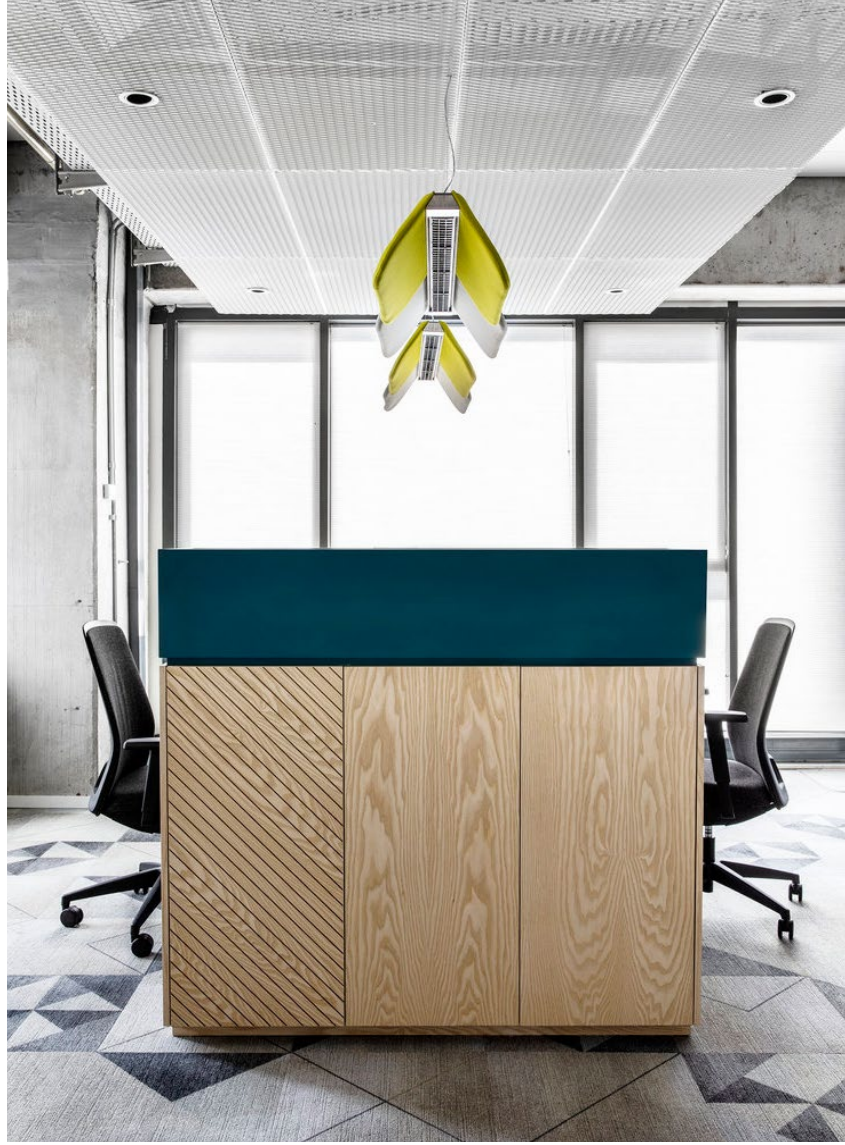



# office

**lighting design for  
offices and sharing spaces  
in Tel Aviv**

**“The approach to  
space planning and  
design derives from  
the identifying needs,  
**desires and dreams of**  
every person, company  
or business. For this  
project, we use existing  
principles and concepts  
of design and adjust  
them to the culture and  
**everyday life”****

**Tel Aviv — 2020**







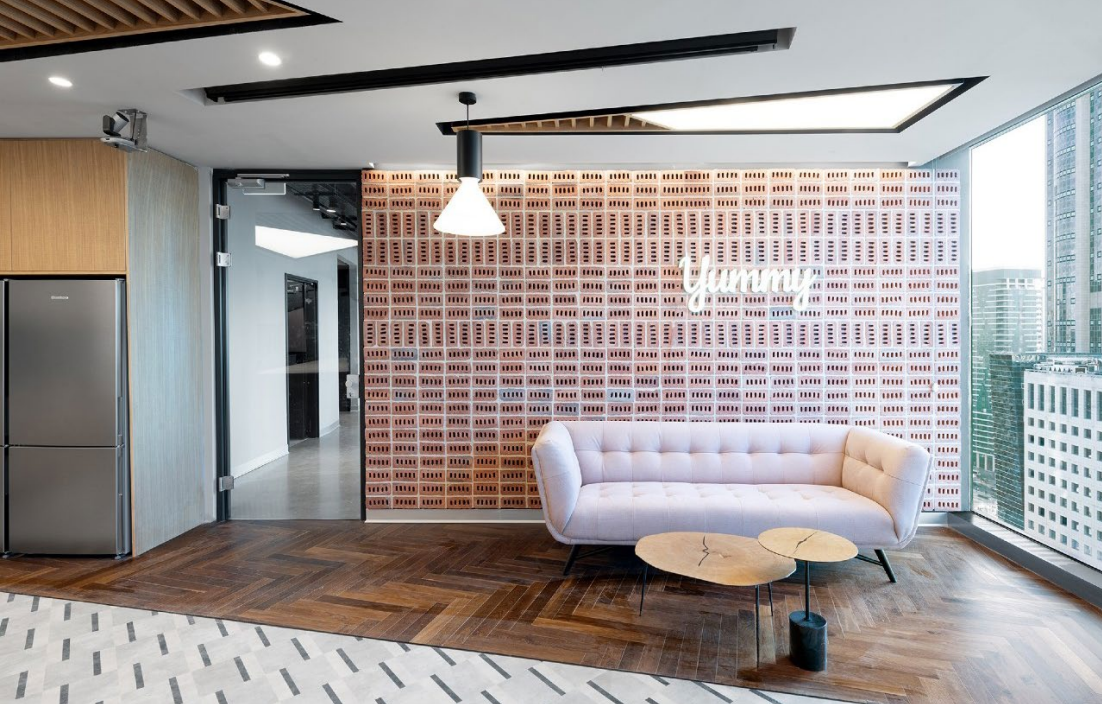



# office

lighting solutions for  
offices and sharing spaces  
of a social media leader  
in Tel Aviv.

“This space is spread  
over four floors in a high  
rise building in Tel-Aviv,  
Israel.

**The project** showed a  
program that **syncs**  
the **company’s values**  
**with a space that**  
**serves its inhabitants.**

It is functional, with  
organic and natural  
features that form an  
optimum setting  
within the urban  
environment.”



Tel Aviv — 2018









# office

lighting solutions for  
offices and common areas  
in Tel Aviv.

“The project was  
designed for a company  
that deals with electronic  
component distributing.  
**The visual identity  
system** of the company  
**played a main role  
in building the design  
language.**

The intention was to  
create a system that  
can be interactive  
and yet low tech and  
timeless.”

Tel Aviv — 2019







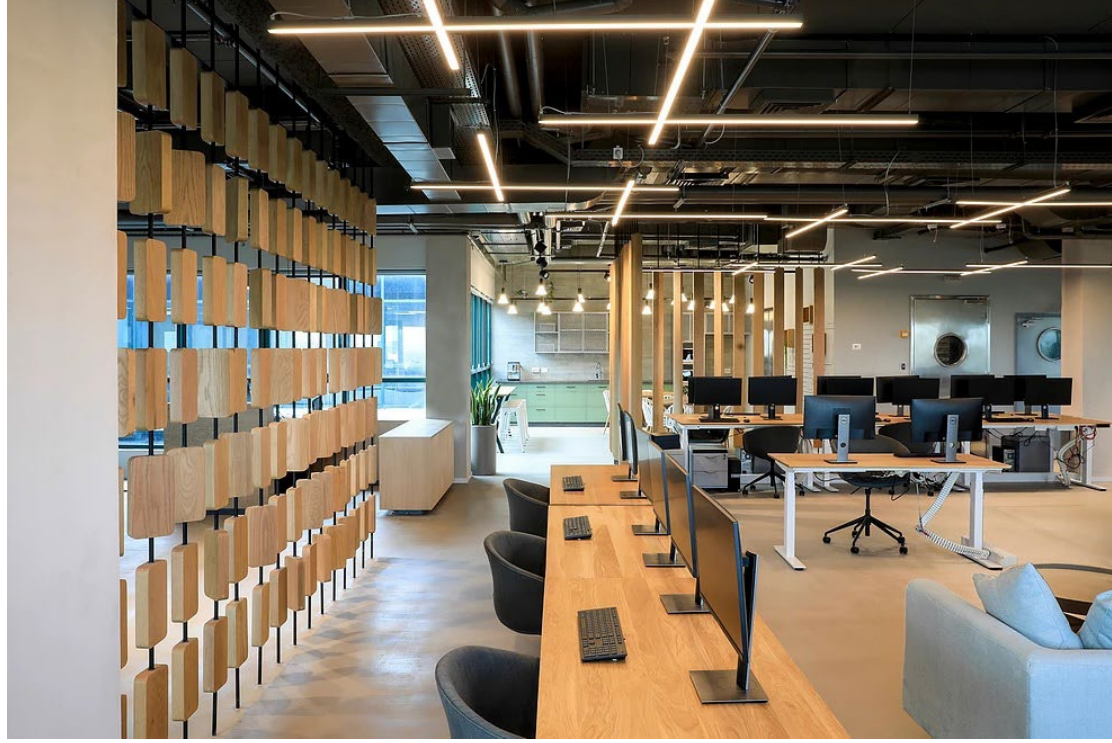
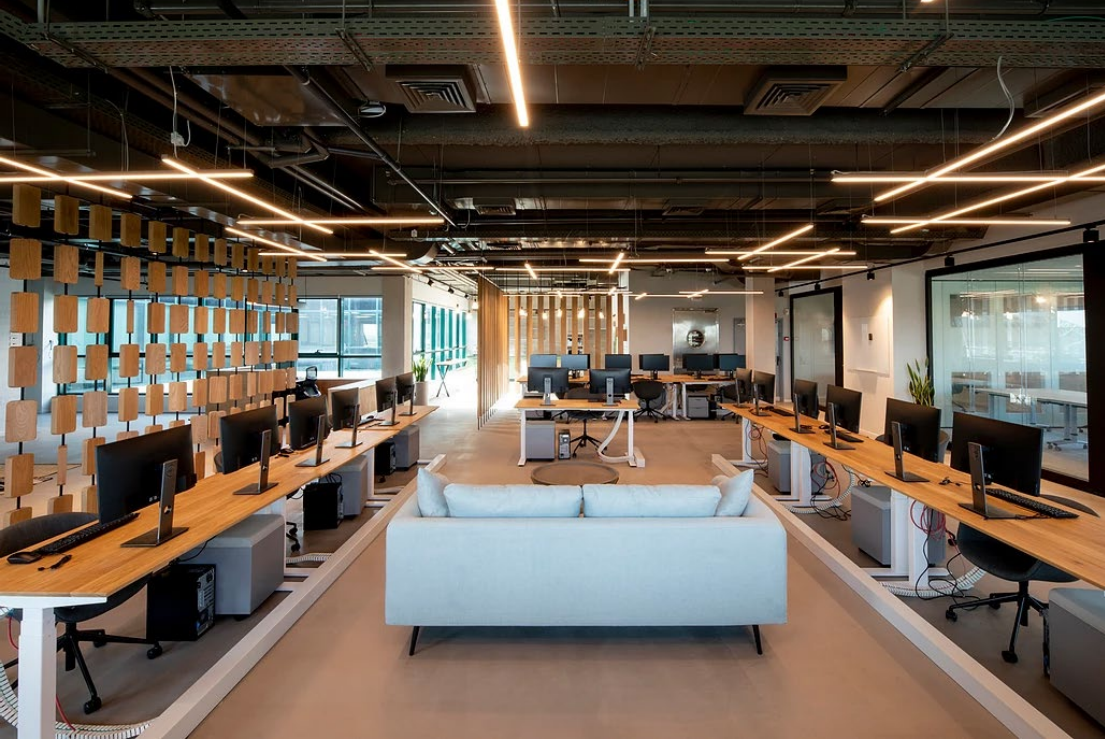



# office

custom lighting  
for a workspace  
in Tel Aviv

“At the beginning of the project we took inspiration Inspired by the **solid shapes of the screens** and an **abstract memory of the wires** and we created several systems including this idea of mass and lines, **body and wires** and this became the language of the design throughout the space.”

Tel Aviv — 2019











# office

custom technicolor  
lighting design  
for a headquarter  
in Tel Aviv

“The projects’ location was studied and taken into account. **Right at the beginning of the project, the city,** a special feature of the new innovation centre **became the main aspect in our inspiration,** and we decided to take the magnificent 360° surrounding city view of the beautiful modern Tel Aviv, and create **an interpretation of the city’s skyline.”**

Tel Aviv — 2018





















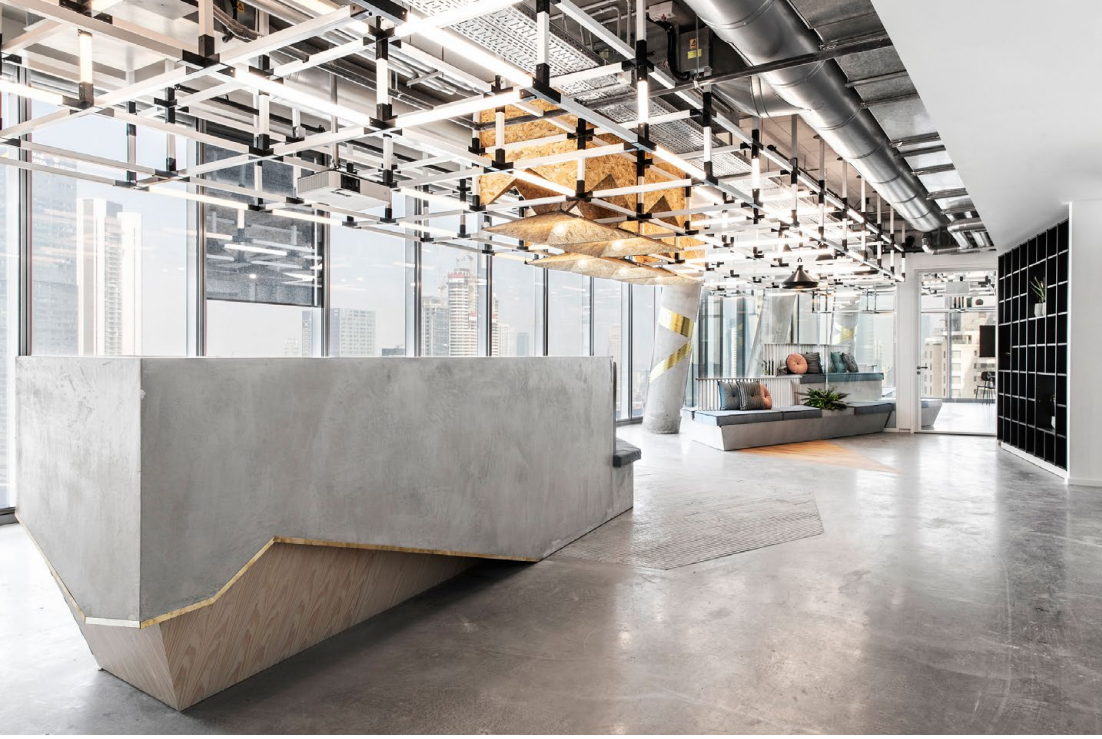







# office

**custom lighting solutions  
for a showroom in Miami**

A showroom is a complex space, with many  
**different areas all with**  
**their specific role,**  
**function and lighting**  
**requirements.**

Creating the right  
atmosphere for any retail  
premise is vital, due to  
the size of the sales  
area, and the size of the  
potential purchase.

**Miami — 2012**









# office

**lighting design  
for the headquarter  
of a hydro-engineering  
enterprise**

AndCosta developed  
the interior concept for  
this hydropower company.  
Andcosta has fully  
supported the enterprise  
in the planning of the  
corporate space.  
Acoustic and lighting  
control played a key role  
in the comfort of the  
space.



**Vicenza — 2012**









# office

**lighting solutions  
for the headquarter  
of a design brand**

AndCosta fully supported the company in the design of the new company space. Lighting played a key role in the building's comfort efficiency.

**Vicenza — 2013**









CATEGORY \_\_\_\_\_  
**public space**



# public space

lighting solutions for the  
new showroom of a  
design brand in München.

Highlighting and  
enhancing the nobility  
of **materials**, the  
sensuality of **shapes**  
and the complex  
drawing of **textures**.  
The purpose of our  
lighting project was to  
give **perfect light to**  
a space lived by **timeless**  
**products** and **ruled by**  
**a minimalistic sensibility.**

München — 2021



photo courtesy © Perennials and Sutherland













# public space

lighting project for a  
climbing room  
located in Vitrolles,  
Marseille

For this custom project  
Andcosta has proposed  
a composition of  
**Circus Round with** bright  
**acoustic panels.**

An area of 1900 m2  
where social interaction  
and well-being are the  
key words.









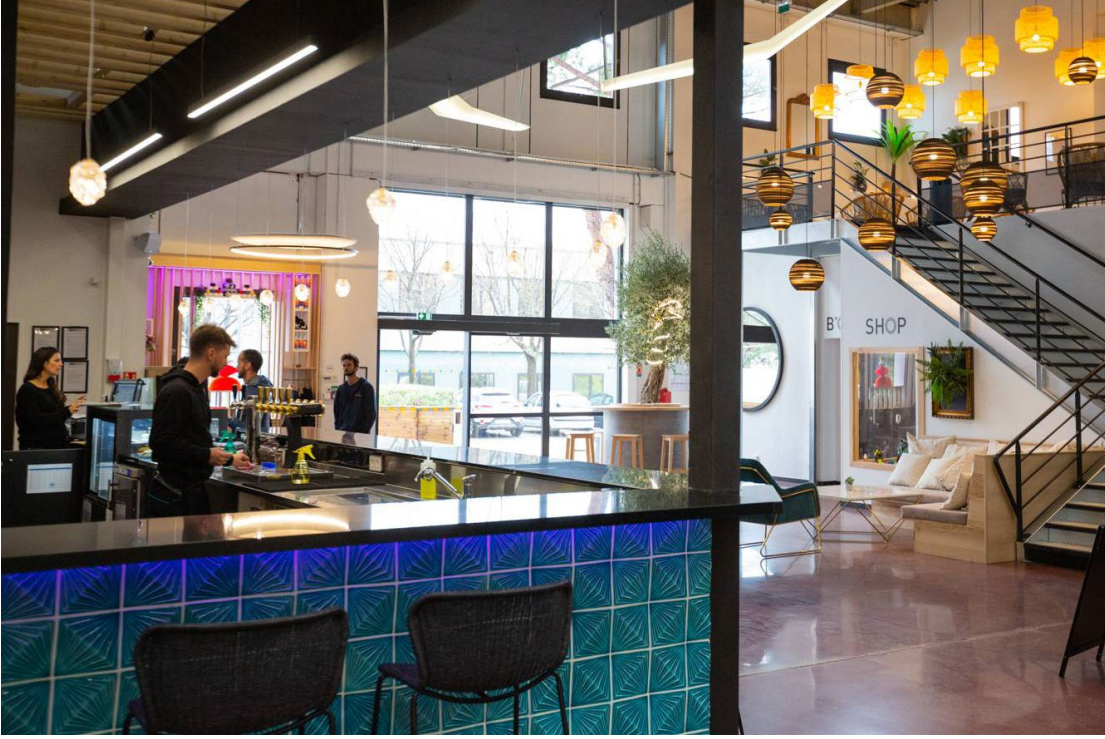

# public space

**task desk-integrated  
lighting solutions  
for a bank in London.**

Qualitative lighting  
design creates  
a positive feeling for  
space and therefore  
improves the work  
of everyone.  
Specifically targeted at  
individual work areas,  
light is only used where  
it is needed.

**London — 2014**







# public space

**spotlights on track  
for a restaurant-bar  
in Tel Aviv**

“The restaurant takes place in a restored ottoman building. Between the typical stone walls and arches the project is a mix of old and new traditions, melting and ottoman roots are perceptible. Humble and minimalist project using natural materials : wood and marble. Brushed brass of the lighting solutions reminds Turkish opulence”



**Tel Aviv — 2017**











# public space

**lamps composition for  
the headquarter of a canadian  
mass-media corporation  
in Toronto**

«Light creates the  
atmosphere and the  
feeling of a place, as  
well as the expression  
of a structure.  
Light is able to  
establish the mood  
of an environment  
and to influence our  
way of perceiving  
what surrounds us in  
a decisive way.»

**Toronto — 2012**



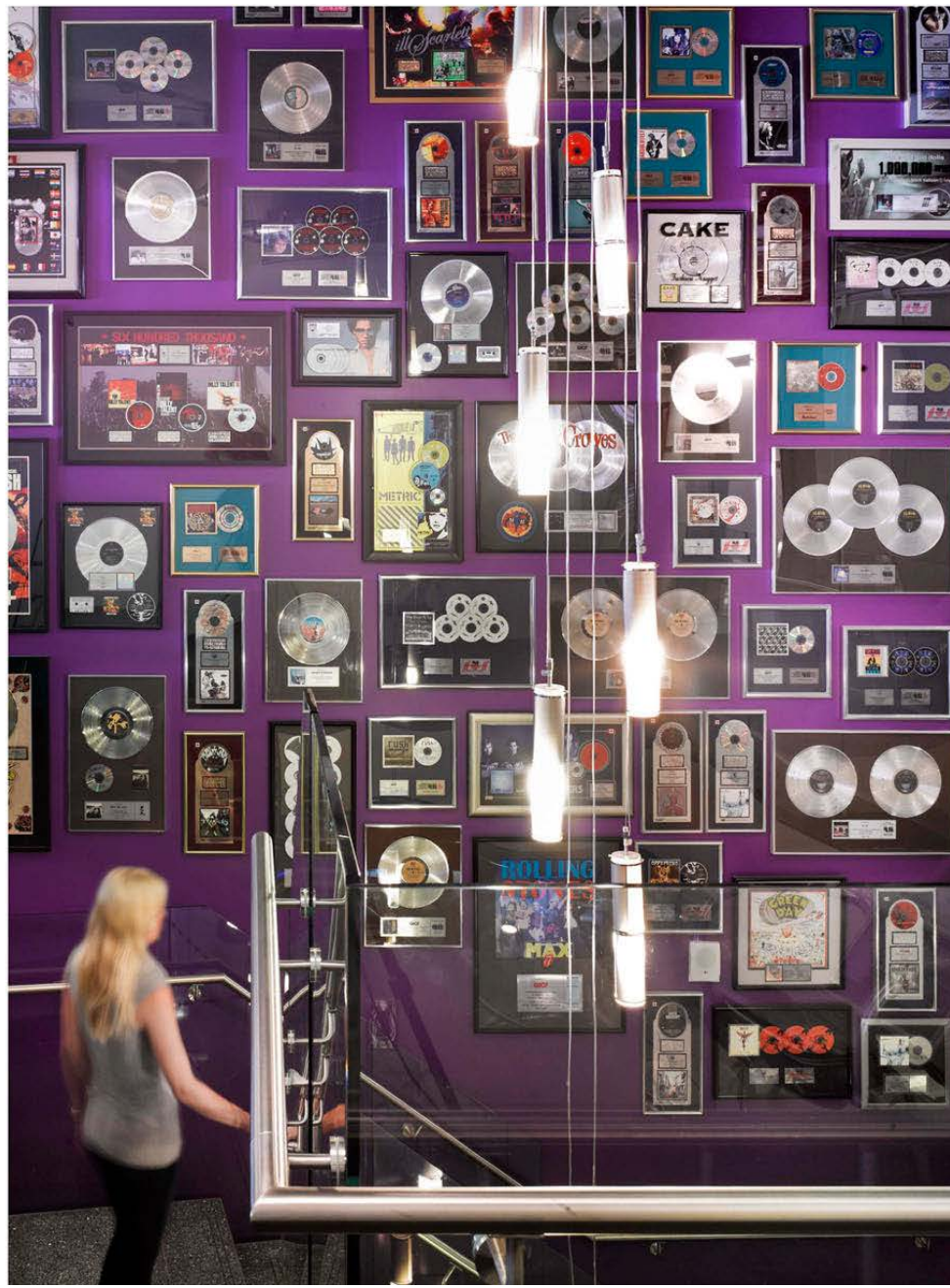



# public space

**hanging lamps composition  
for a design brand  
in Düsseldorf**

The installation,  
created by adapting  
a catalog product,  
creates a visual  
suggestion thanks to  
its slight and  
floating shape.

**Düsseldorf — 2018**

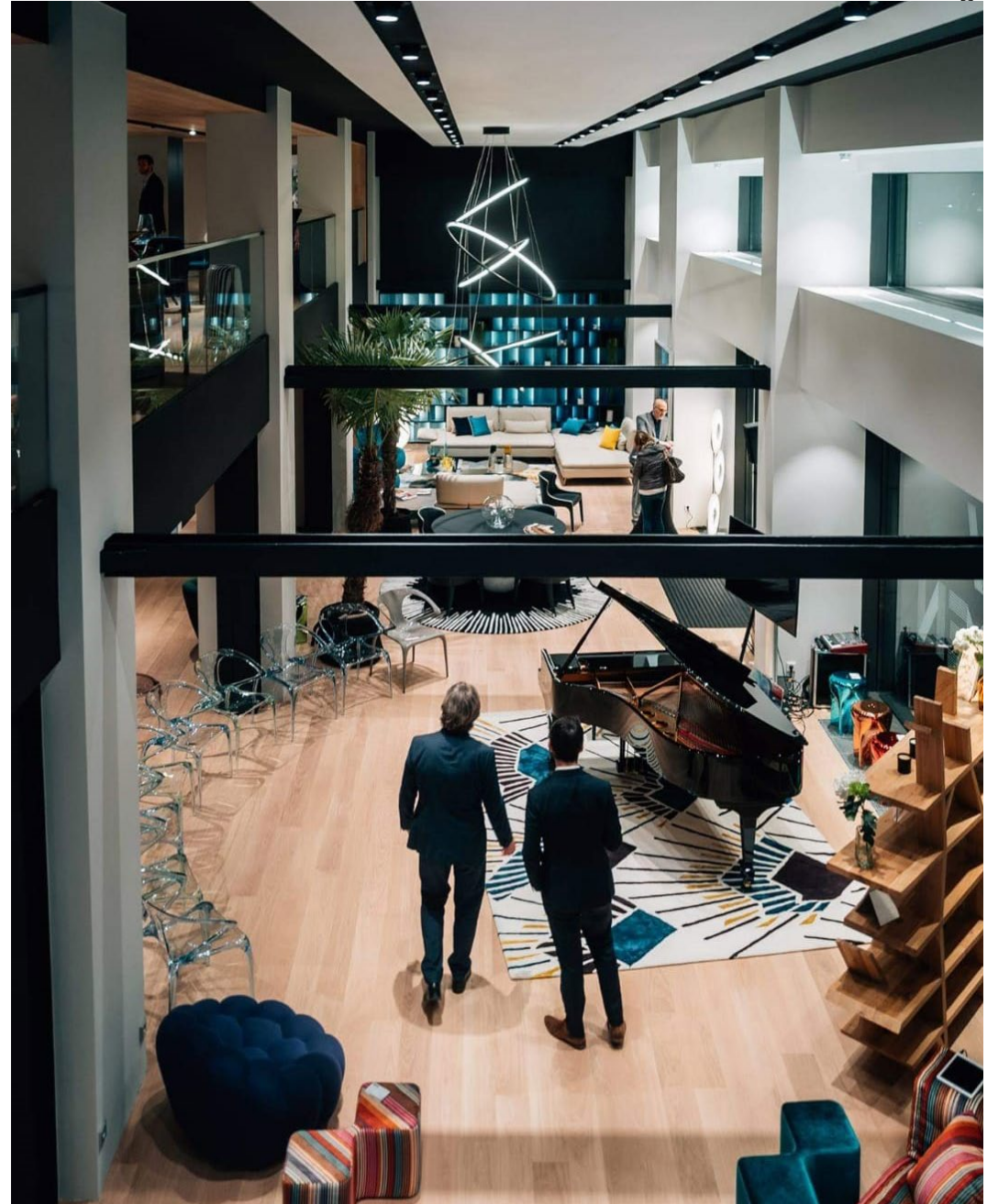

SUMMARY \_\_\_\_\_

**custom  
developing  
process**





# phase 1

**we begin** Starting from our client's input, we begin a deep reserch through the existing solutions led by the aim to achieve the best results possible. Always taking care about user needs, we gather the informations to start the developing phase.

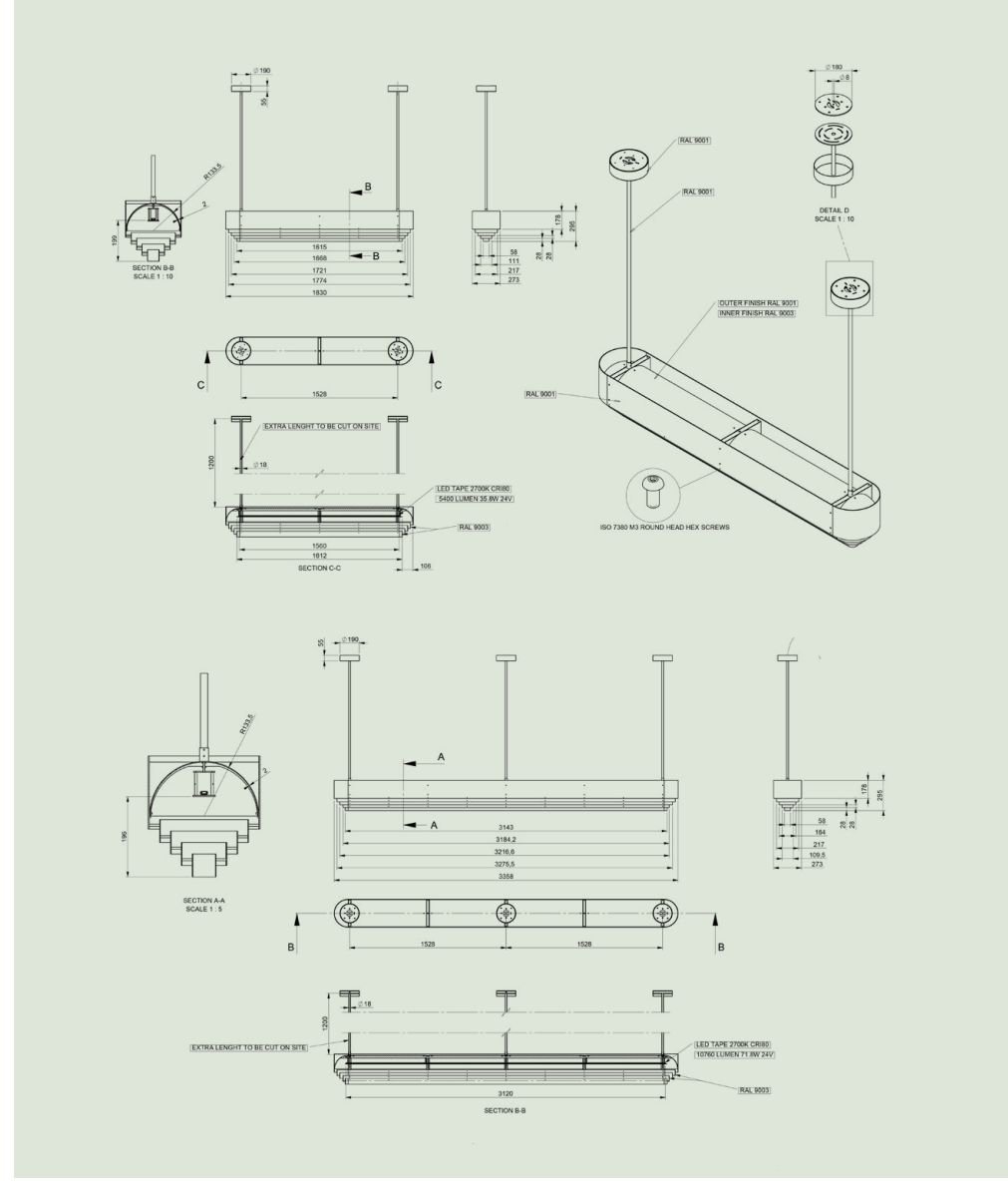

## phase 2

**we develop** Technical office provides to set dimensions, materials and technical details to get the best result possible comparing the available alternatives. Best performance, best technologies and competitive time of development.

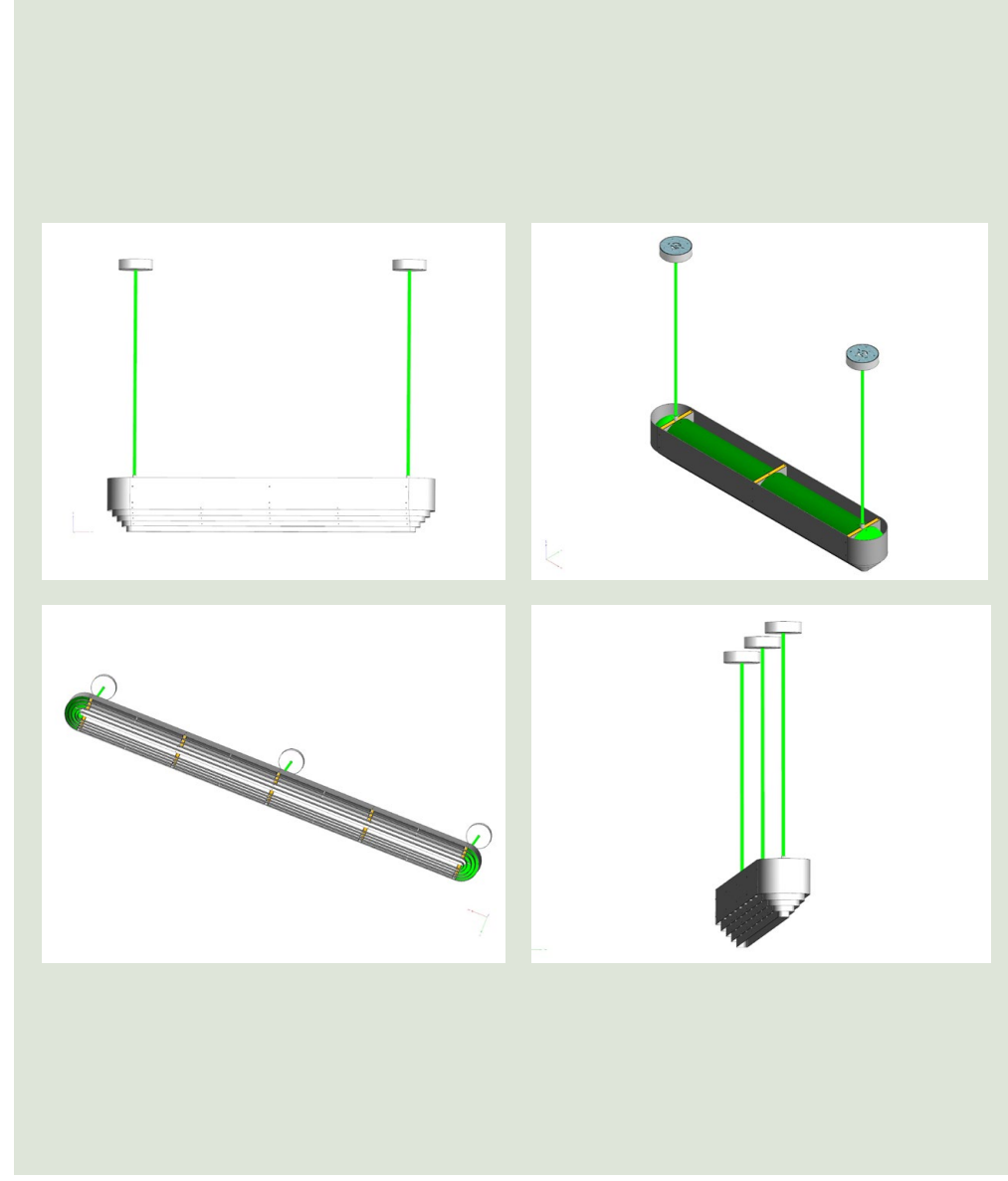



the process



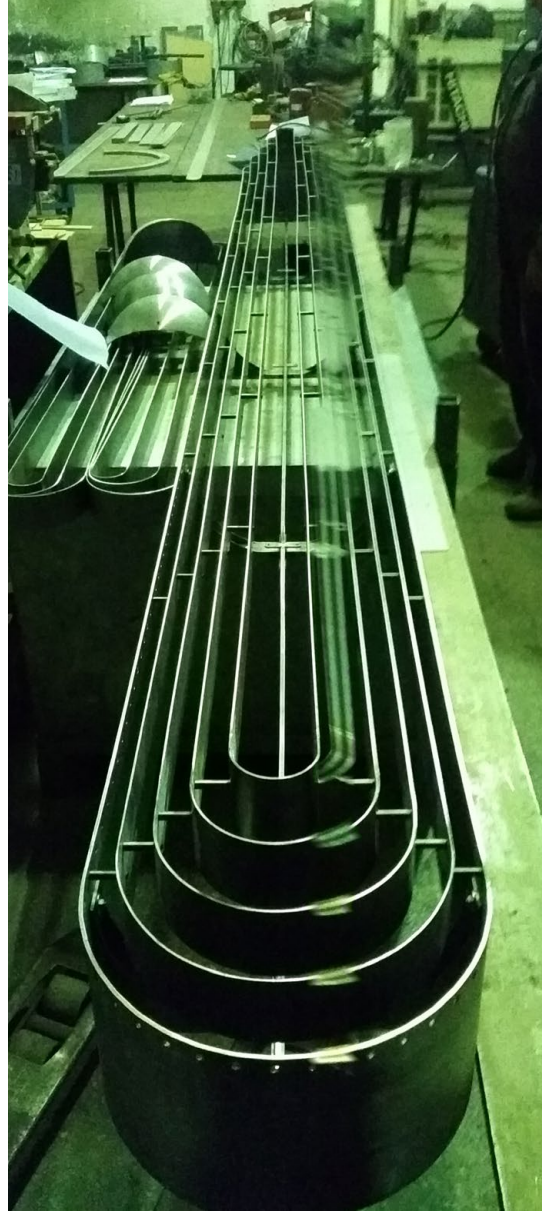



the process

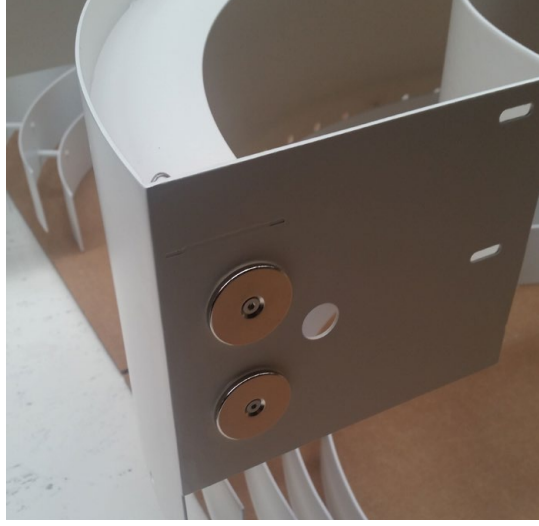

the process

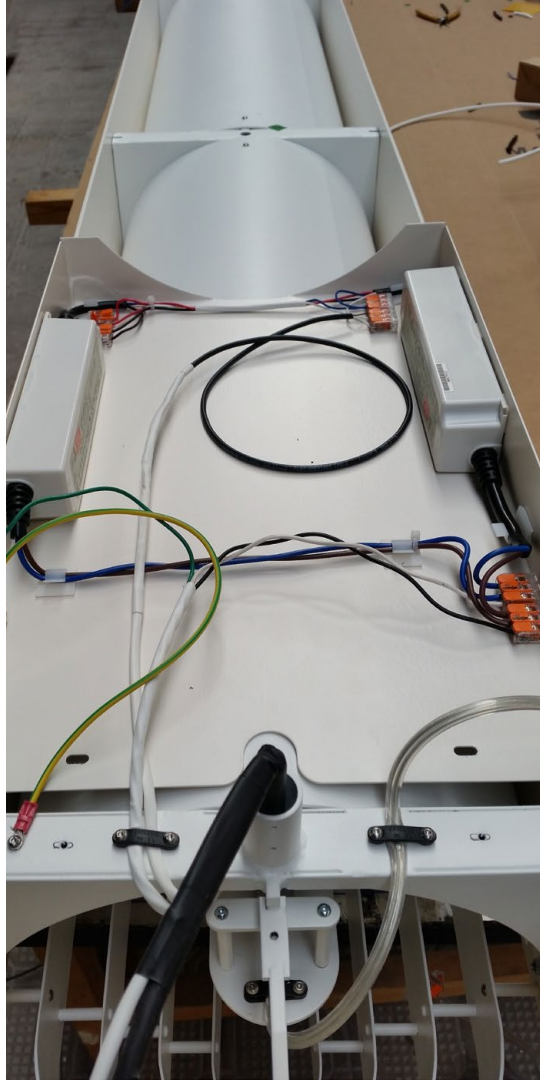



the process

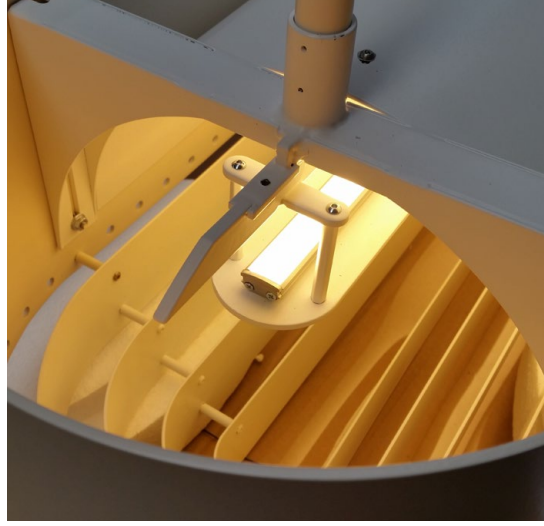
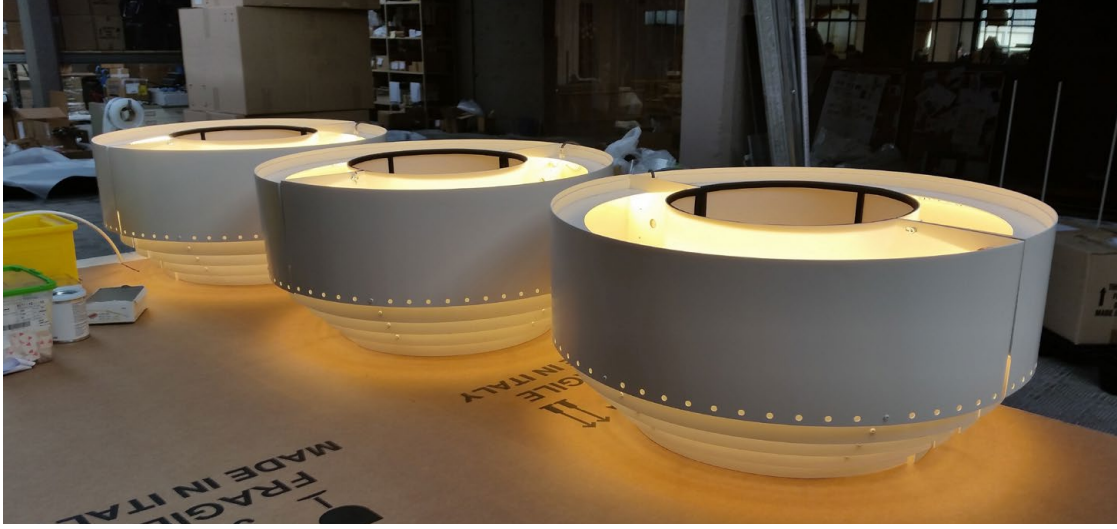

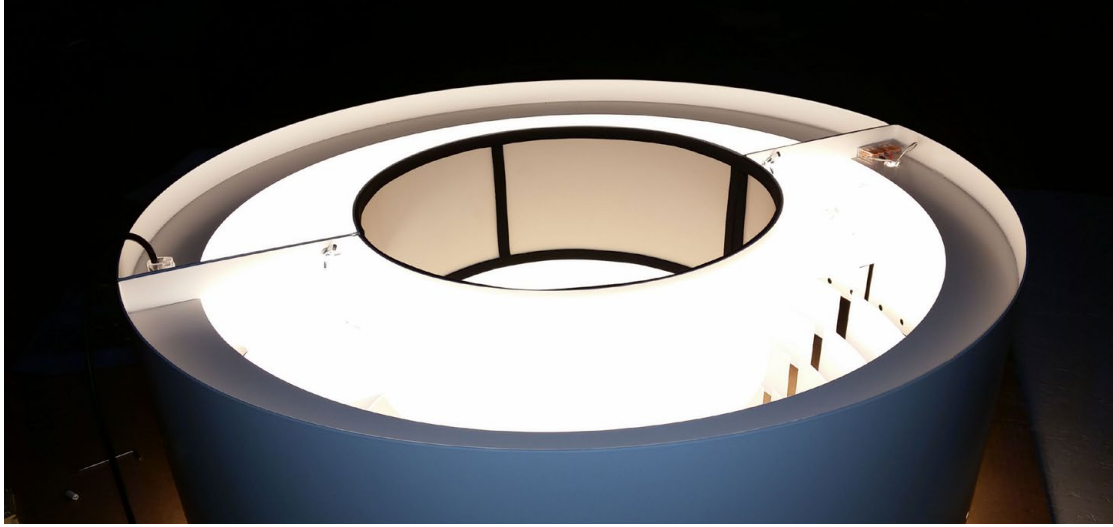



## phase 3

**until installation**

Andcosta provides continuous support throughout the entire course of a project and our team is always on hand to provide professional and constructive advice.







REFERENCE

---

**W Amsterdam**, Amsterdam

**Jaffa**, Tel Aviv

**GANG**, München

**Perennials and Sutherland studio**, München

**CEA design**, Italy

**Zeco Hydropower**, Italy

**Wyndham**, Frankfurt

**OMM Sir Victor**, Barcelona

**Nuvo group**, Tel Aviv

**Natural Intelligence**, Tel Aviv

**Wells Fargo bank**, New York

**Natixis Bank**, London

**la Triennale**, Milano

**Facebook**, Tel Aviv

**IBM**, Tel Aviv

**lenovo**, Tel Aviv

**Bentley** Showroom, Canada

**Adotta Inc.**, Miami and Englewood

**Corus Entertainment**, Toronto

**Hollywood film industry**, Los Angeles

**Chicago O'Hare International Airport**, Chicago

**Hyatt Monterey**, California

**SisterCity hotel**, New York

**Kishle**, Tel Aviv

**Biennale Venezia**, Venezia

and more:

**private residences**

**hospitals**

**public spaces**

**universities**

**art galleries**

**lighting design**



**made in Italy**

**AndCosta** is based near Venice, an area that loves design and culture, past and present, craftsmanship and beauty. The company Andcosta is a space for research and planning of lighting design. Rooted in the traditions of Italian design, it creates lighting objects that reflect functionality and timeless beauty in their style.

The company is located inside the walls of the **historical textile mill** of Thiene's town – an evocative place surrounded by the Venetian Prealps and home to the renaissance architect **Andrea Palladio**, the space is rich in culture and artisanal craft traditions, where the past and present represent the birth of the **Italian manufacturing industry**.

The restoration of this mill building, with its **industrial archeology**, has preserved its existing structure, enhancing and adapting its spaces to the requirements of our company.

The industrial architecture was skillfully restored and renovated and its **4000 sq metres of floorspace** now hosts the company's administration offices, the graphics and design team, production and logistics, a photo studio, showrooms as well as meeting and collaboration space. In a place where once textile products were made, now ideas and lighting objects are designed.



All rights reserved.  
No part of this publication  
may be reproduced, stored  
in a retrieval system  
or transmitted, in any form  
or by any means, electronic,  
mechanical, photocopying,  
recording or otherwise,  
without the prior permission  
of AndCosta.  
AndCosta reserves the right  
to introduce any changes  
to its own model, without  
prior notice.

Graphic design: AndCosta  
Feb 2022

© AndCosta. All rights reserved.



Via delle Pastorelle 6  
36016 Thiene (VI) ITALY  
+39 0445 873517  
info@ecosta.it  
andcosta.com



