

# CATALOGUE 2023

lighting design made in Italy



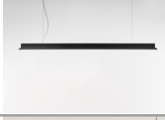

#architectural

<b>4</b> b-pro basic	
<b>10</b> b-pro system	
<b>21</b> circus	
<b>42</b> acoustic panel	
<b>50</b> volare	
<b>56</b> cyl	
<b>66</b> daytona	
<b>76</b> duplo	
<b>83</b> luna	
<b>97</b> monocolo	

<b>104</b> nova	
<b>116</b> ritmo	
<b>128</b> vitreo	

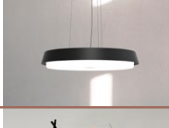
#decorative

<b>139</b> armando	
<b>144</b> cone	
<b>154</b> flat	
<b>158</b> grue	
<b>164</b> klokke	
<b>170</b> mecano	
<b>178</b> peak	
<b>185</b> pin	
<b>201</b> pop	
<b>206</b> riga	
<b>210</b> steel arc	
<b>216</b> tessa	
<b>224</b> tre	
<b>231</b> turn	
<b>236</b> vento	
<b>242</b> you	

COLLECTION

**ARCHITECTURAL**

**ANDCOSTA**

COLLECTION

**b-pro**

**ANDCOSTA**

# b-pro

Technology merges with architecture in sublime lighting with a minimalist expression, defining space by tracing elegant geometrics that float in space.

Its minimal light source provides multiple options for lighting.

Both the **BASIC** and **SYSTEM** versions are minimalist in style, yet they offer endless configuration options. The minimalist body is the essence of multiple lighting and configuration possibilities, especially thanks to the use of an articulation which when anchored to different surfaces, in the SYSTEM version, **enables the creation of unique geometries.**

Individual ultra-fine optical systems provide very sharp direct and indirect light.

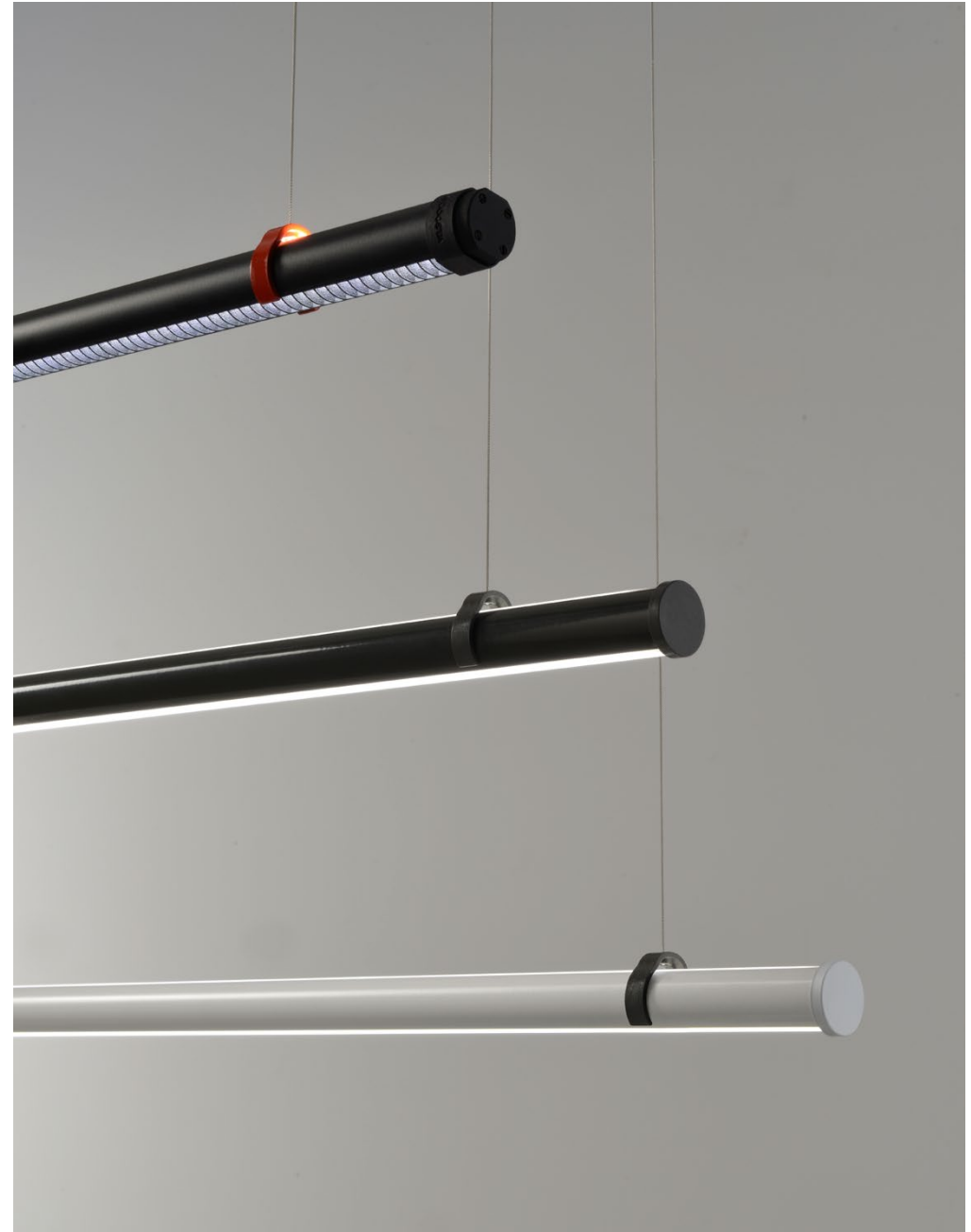

DESIGN AndCosta Team — 2022

discover B-PRO on our website



# b-pro BASIC

**Hanging lamp with direct  
and indirect light.**  
Aluminium structure white,  
black or grey coated.  
Opal polycarbonate diffusers.  
Strip LED.

Available dimensions:  
**1000, 1200, 1800,  
2400, 3000 mm.**

**Accessories:**  
- fiberglass reinforced  
ABS **suspension clips**  
available in white,  
black, grey, brass and  
red finish;  
- **separate switch**  
direct/indirect.

**DESIGN AndCosta Team** \_\_\_\_\_ **2022**



discover B-PRO on our website





b-pro basic S1800



mm/inch

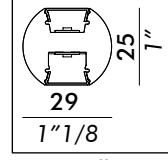
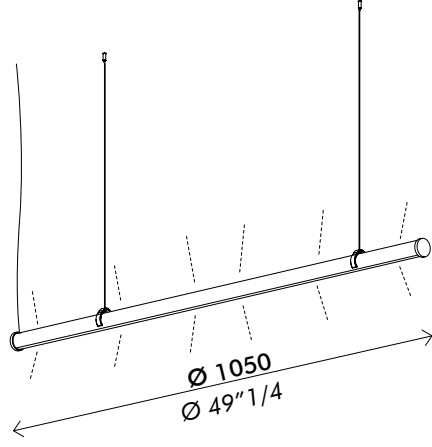

opal diffuser



b-pro basic S1000

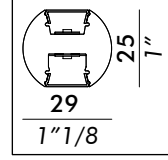
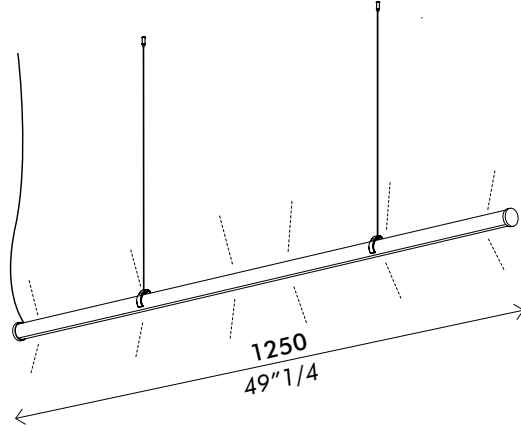

opal diffuser



b-pro basic S1200



mm/inch

**b-pro basic S1800**

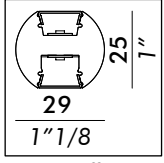

opal diffuser

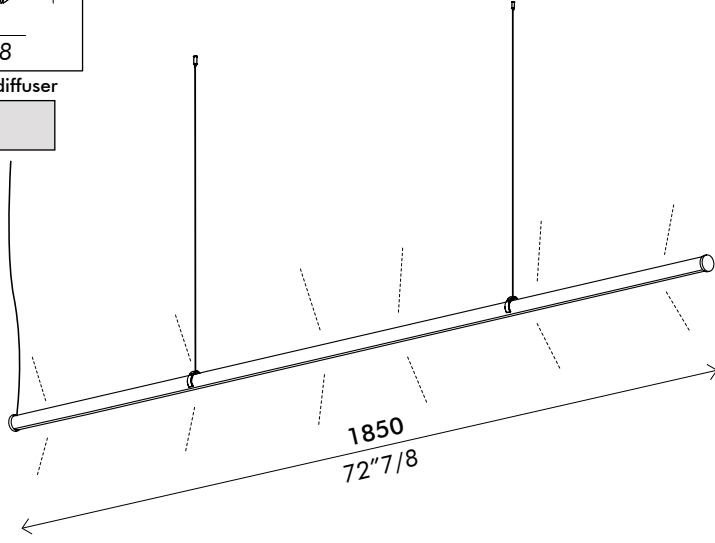

**b-pro basic S2400**

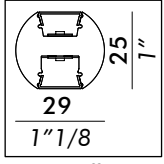

opal diffuser

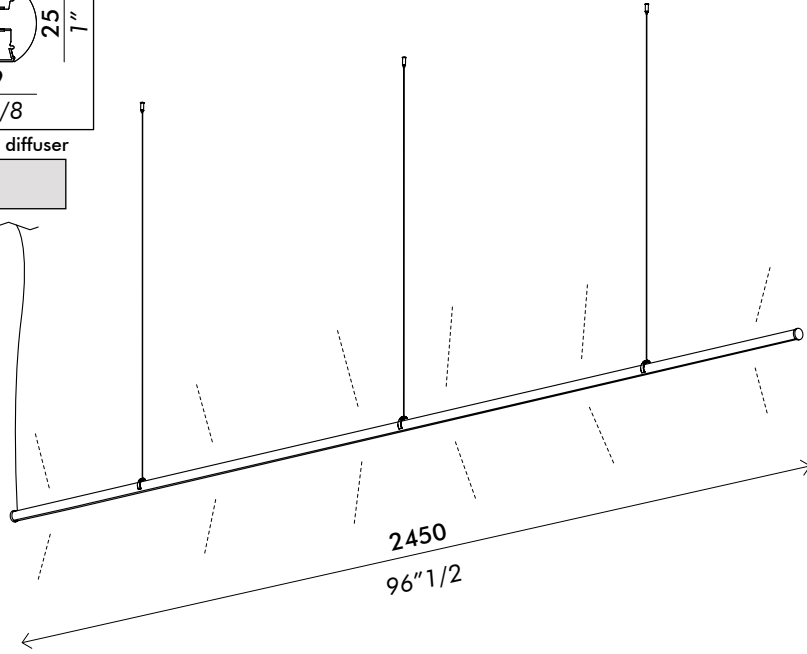

**b-pro basic S3000**

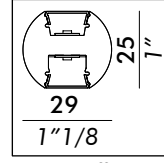

opal diffuser

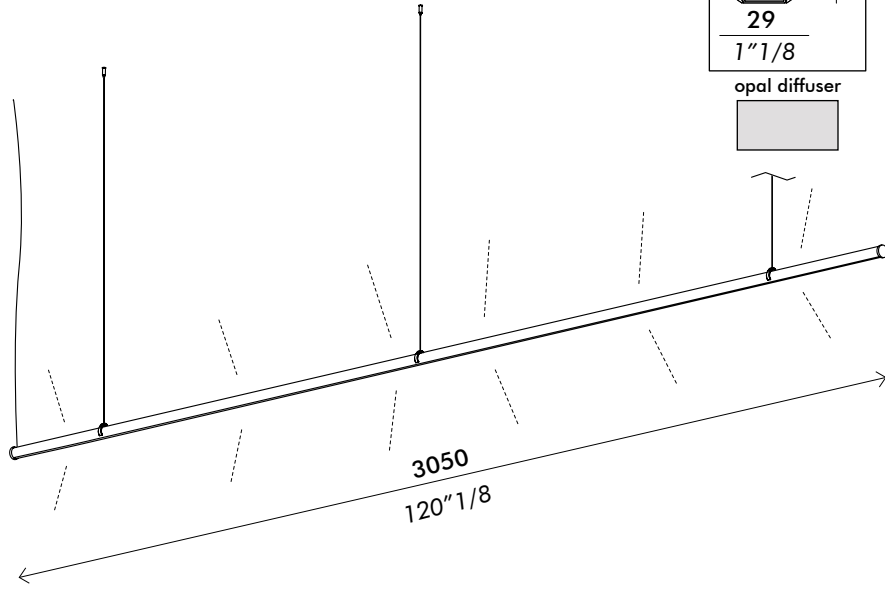

# b-pro SYSTEM

Lighting modular system with direct and indirect light connectable together or available in a standalone configuration. Aluminium structure white, black or grey coated.

Opal polycarbonate upper diffuser and opal polycarbonate or darklight optic lower diffuser. Strip LED on polycarbonate diffuser or LED module on darklight optic diffuser.

Available hanging lamps dimensions: **1000, 1200, 1800, 2400 and 3000mm.**

### Accessories:

- fiberglass reinforced ABS **suspension clips** available in white, black, grey, brass and red finish;
- polyamide 12 **wall joint support**;
- **separate switch** direct/indirect.

DESIGN AndCosta Team ——— 2022



[discover B-PRO on our website](#)





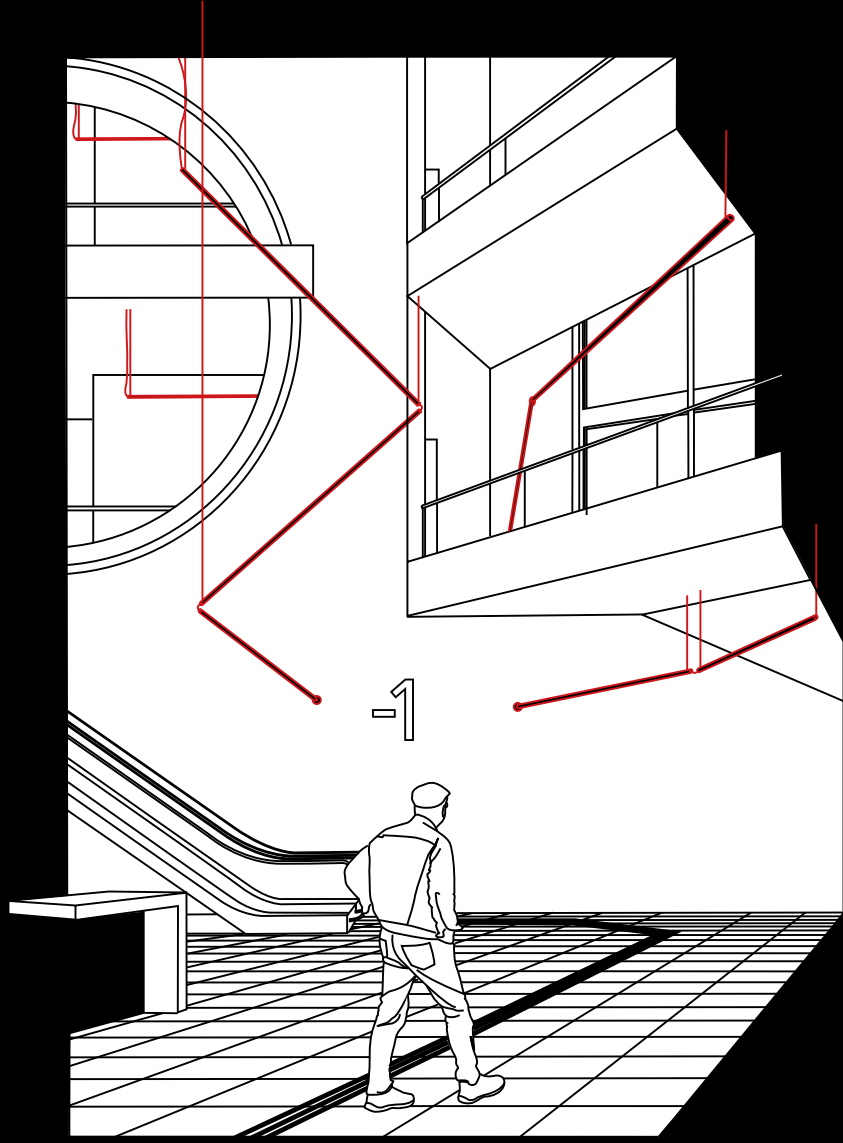
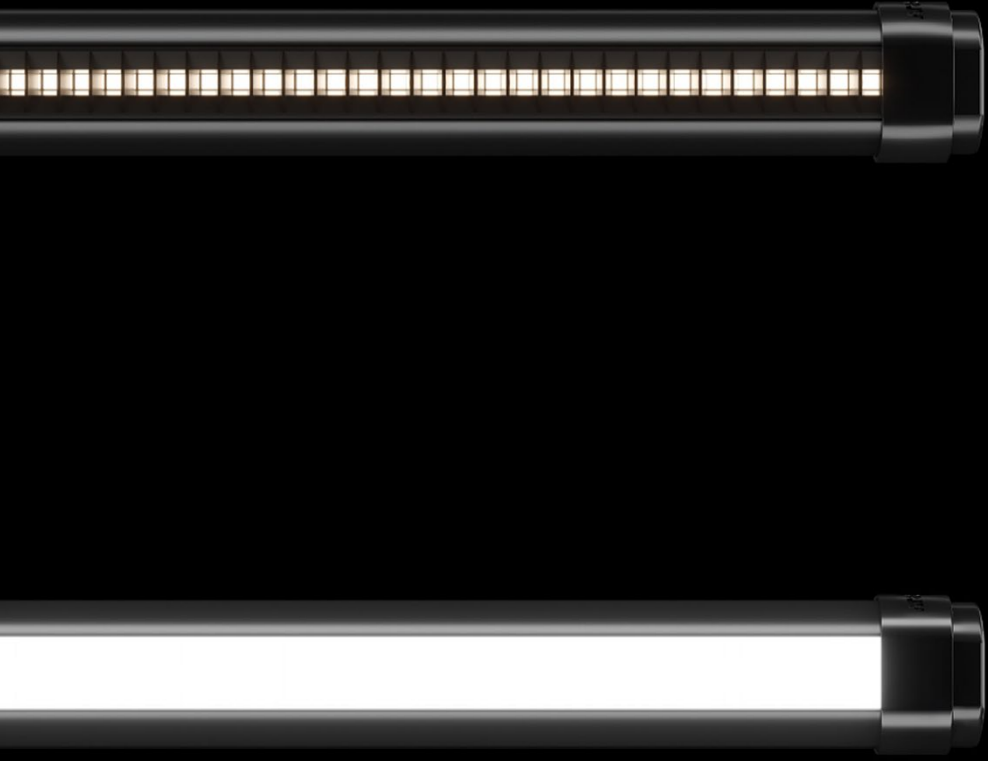

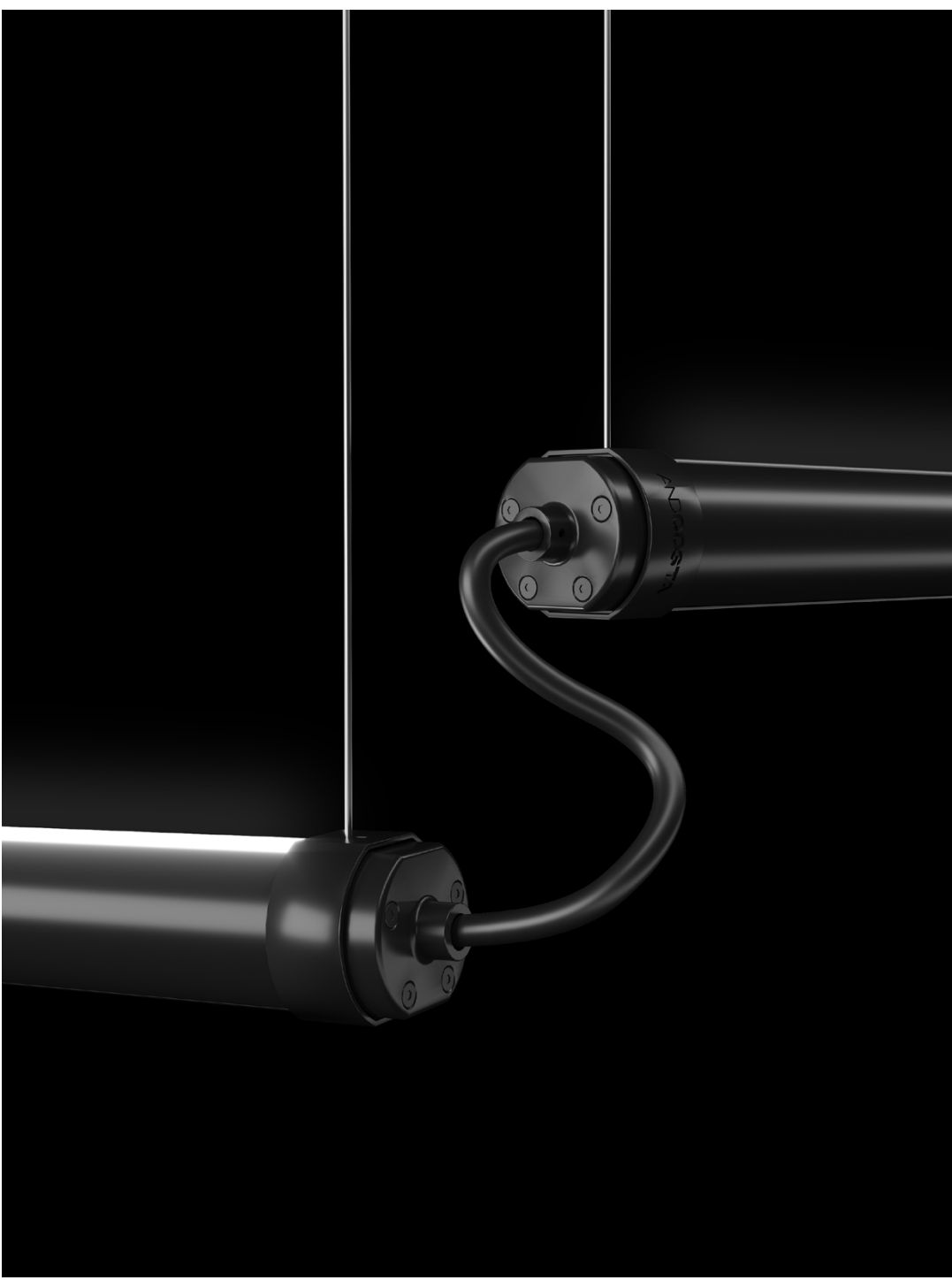

# Use B-PRO SYSTEM to compose your own lighting environment

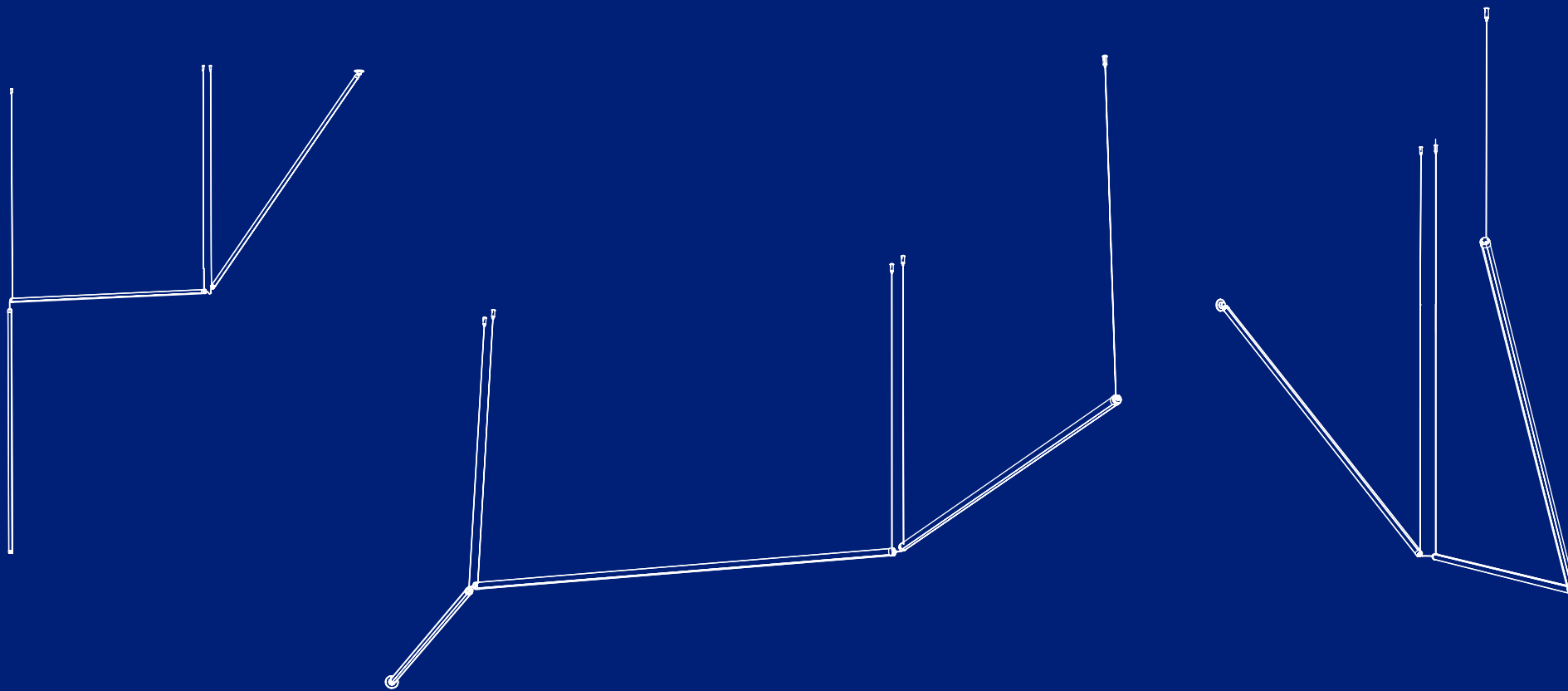

# sizes

Our toolkit provides stand-alone biemission modules in 5 different sizes:  
1000, 1200, 1800, 2400 and 3000 mm.



B-PRO system elements can be joined one to each other to a total maximum length  
of 3 meters per single electrical connection.

# optics

According to your needs you can choose the opal filter for more diffused light or the darklight optic which, thanks to its grid, sections the light beam of the high-efficiency LED into miniature alveoli, drastically reducing glare and improving visual comfort.





# applications

B-PRO System elements can be connected together in the following ways:  
wall-to-ceiling, wall-to-wall, ceiling-to-floor or pendant.

wall-to-ceiling

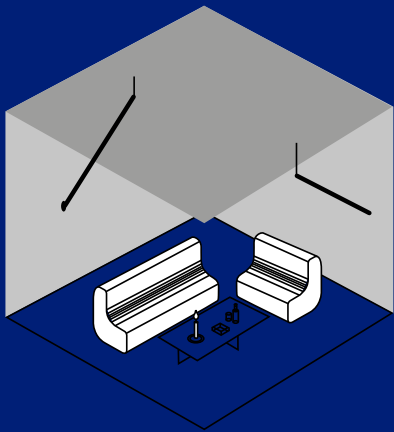

wall-to-wall

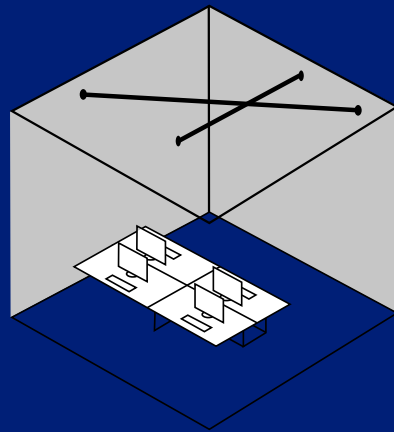

ceiling-to-floor

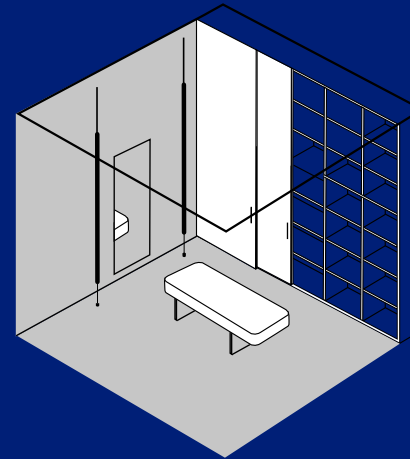

pendant

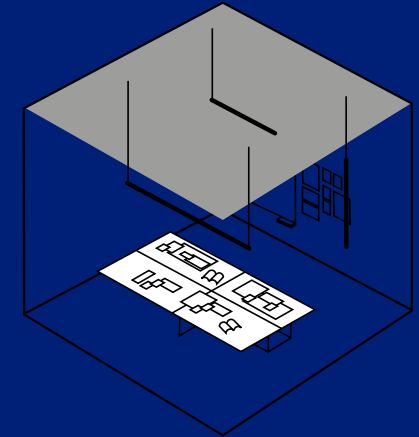

You can design your light pattern adding connectable B-PRO System modules moving into space with endless possibility of layouts.

The use of a wall joint which can be anchored to to different surfaces, enables the creation of unique geometries.

# composition example

toolkit:

1 x

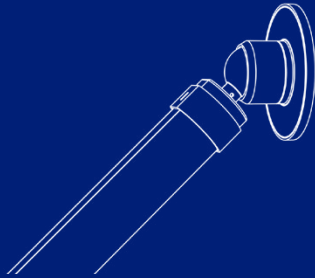

5 x 1800 mm



4 x

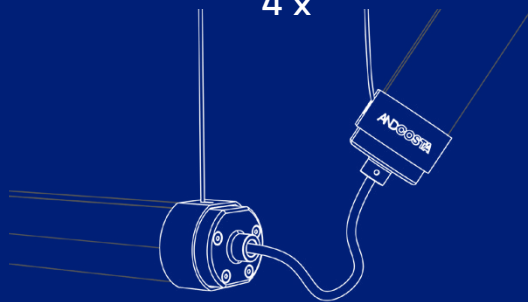

final result:

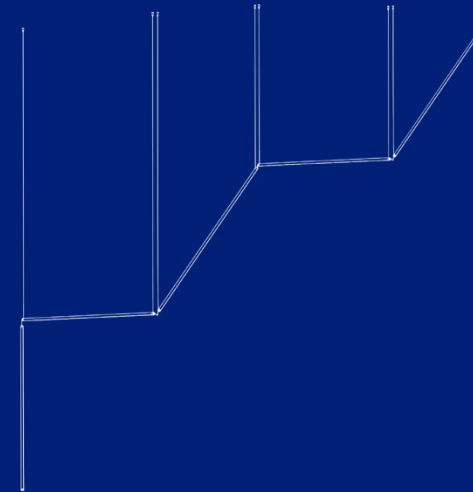

mm/inch

**b-pro system S1000**

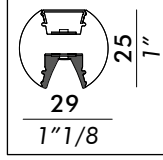

dark light diffuser

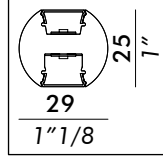

opal diffuser

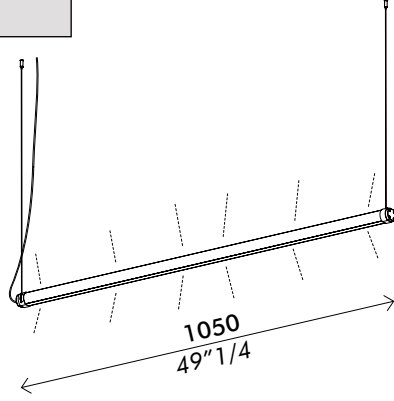

**b-pro system S1200**

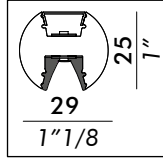

dark light diffuser

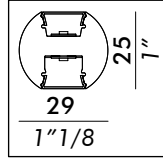

opal diffuser

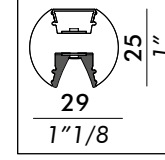
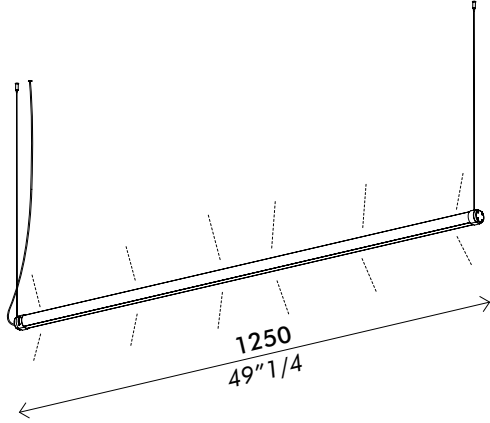

dark light diffuser

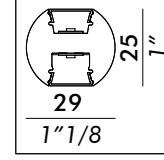

opal diffuser

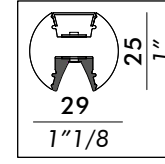
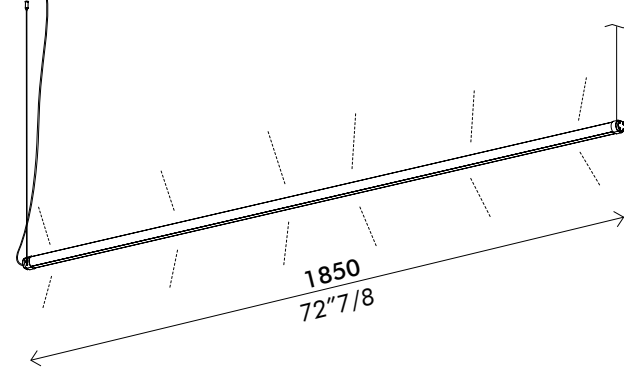

dark light diffuser

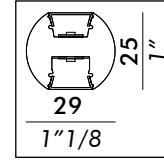
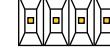

opal diffuser

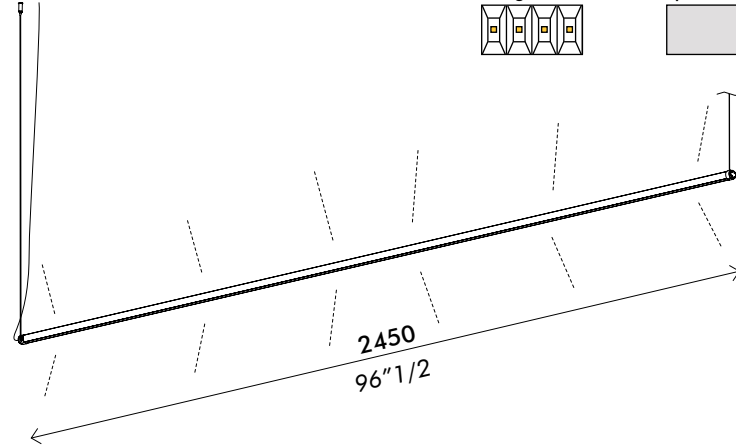

**b-pro system S1800**

**b-pro system S2400**

mm/inch

**b-pro system wall joint support**

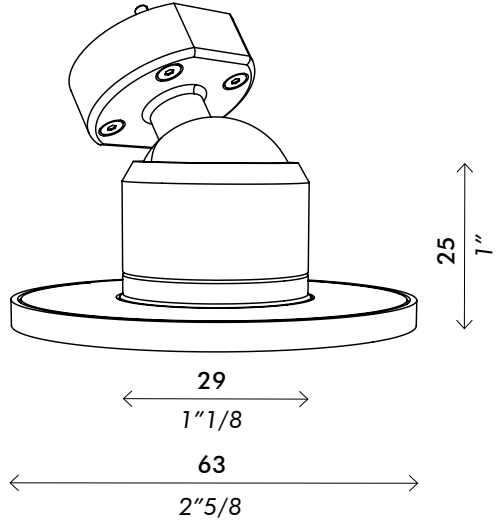

**b-pro system S3000**

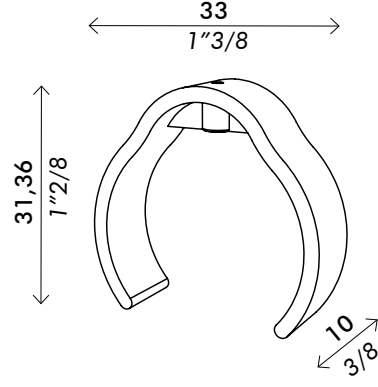
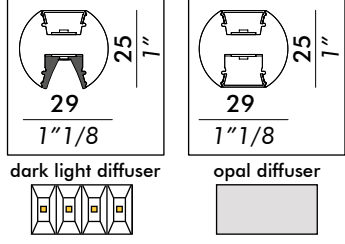
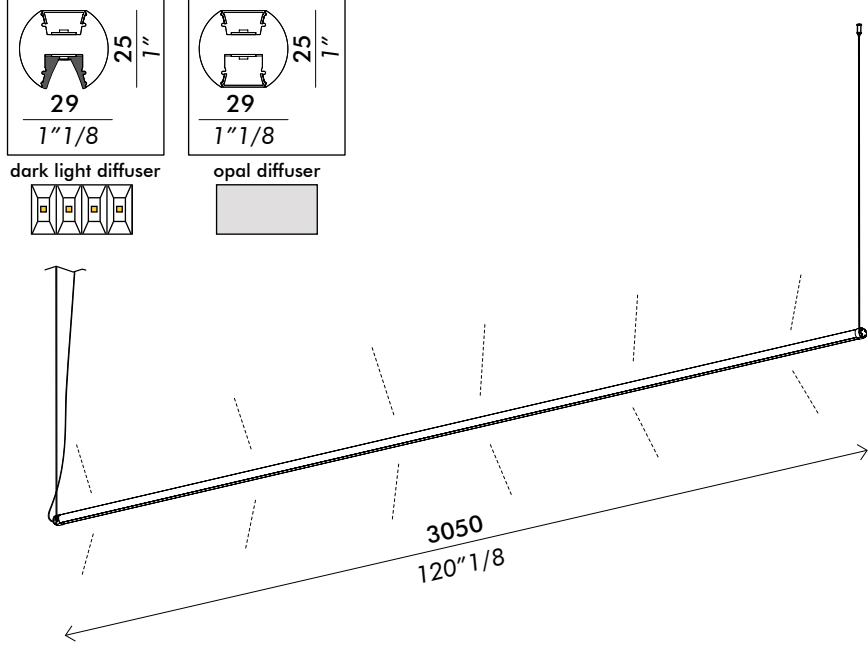

**b-pro suspension clip**

COLLECTION

**circus**

**ANDCOSTA**

# circus

**Hanging lamps with diffused light.**  
**Aluminium structure matt white,**  
**black or brass coated.**  
**Opal polycarbonate or transparent**  
**prismatic diffuser.**  
**Metal ceiling canopy matt white,**  
**black or brass coated.**  
**Strip LED.**

A system for architectural lighting and acoustic control.  
The circus modular and suspended shapes represents ideal tools for variable sized showrooms, collective areas and workspaces.  
The collection includes  
**Circus round,**  
**Circus square,**  
**Circus rectangular,**  
**Circus linear and**  
**Circus multiround.**

**DESIGN Carlo Zerbaro — 2015**



discover CIRCUS on our website







mm/inch

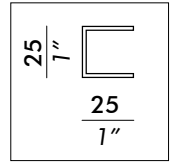
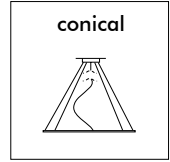
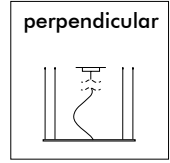
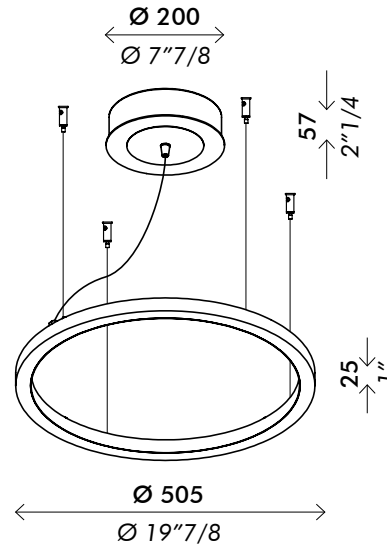

circus round S500

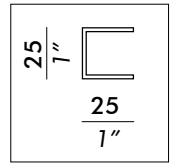
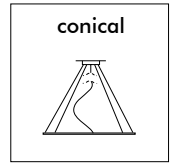
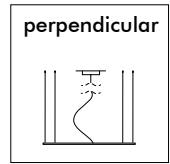
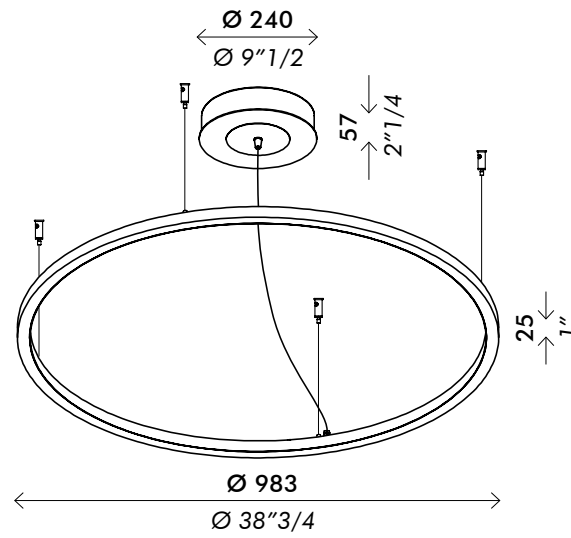

circus round S1000



**circus round S1500**

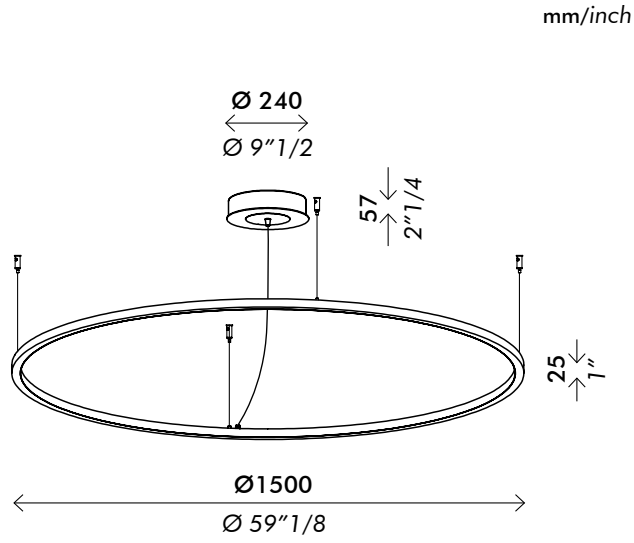
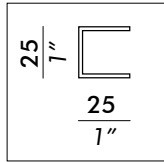
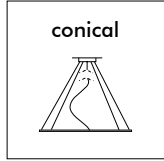
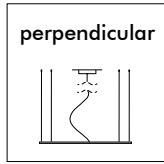

**circus round S1000**

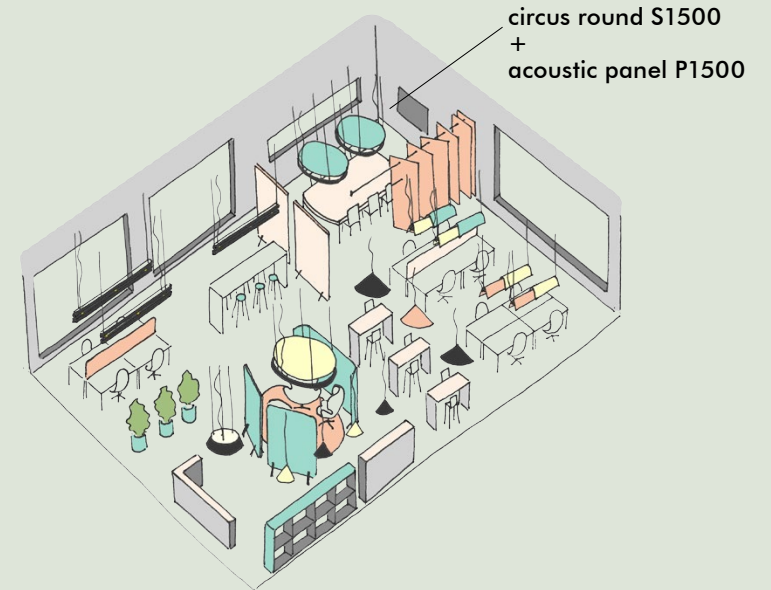
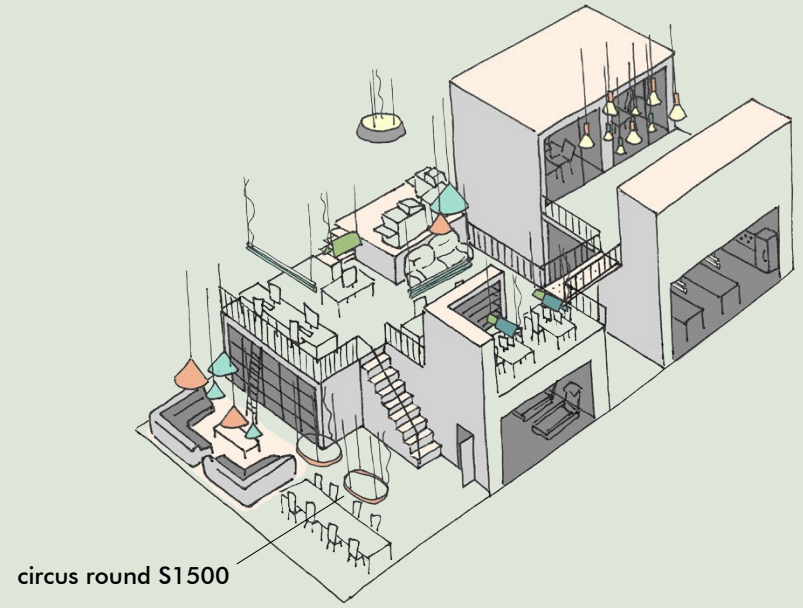
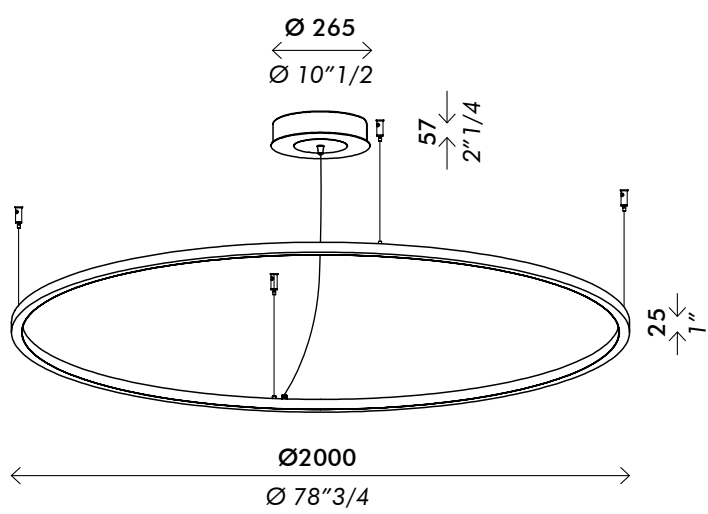
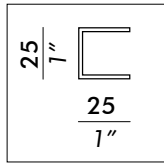
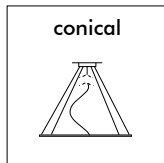
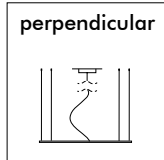



circus round S1500 and S500 vertical

mm/inch

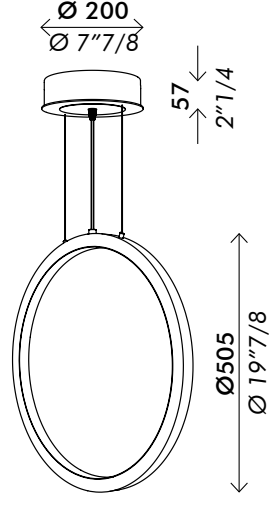
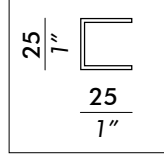
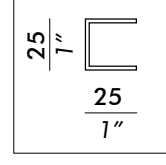
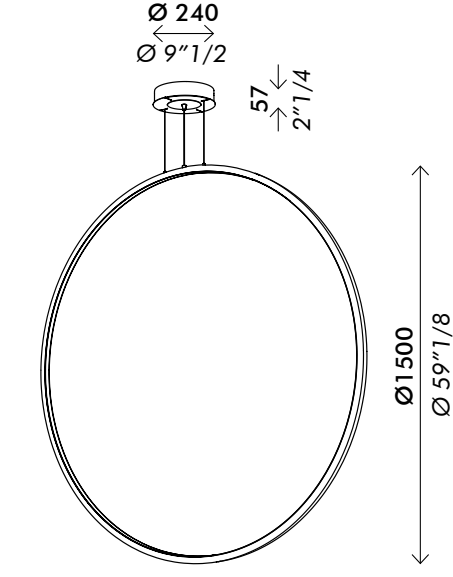
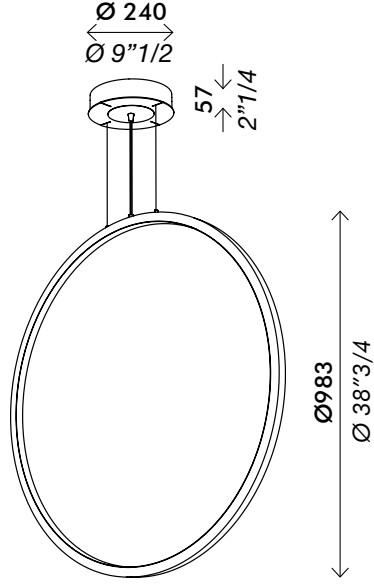
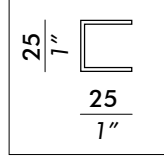
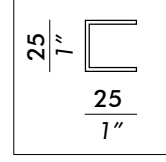
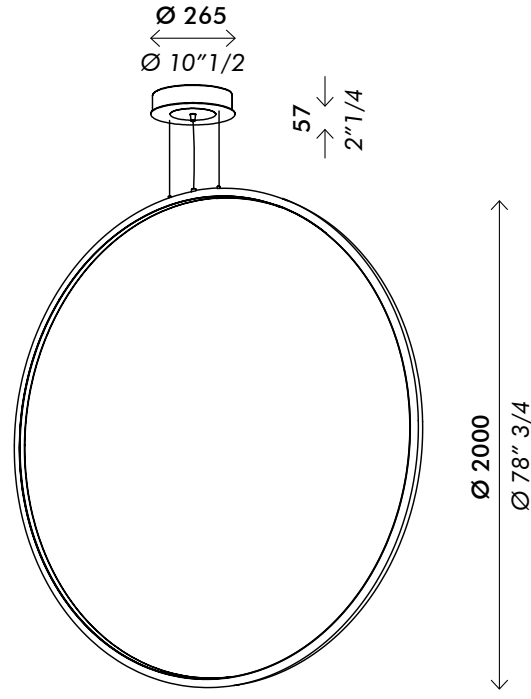
circus round S500 verticalcircus round S1000 verticalcircus round S1500 verticalcircus round S2000 vertical



circus oval S1600

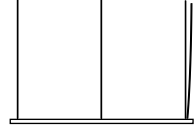
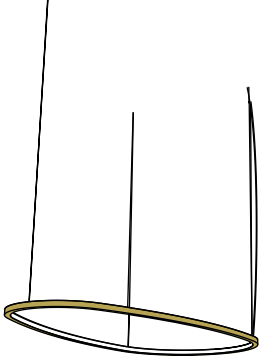
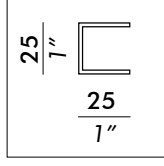

±810 mm  
± 32"

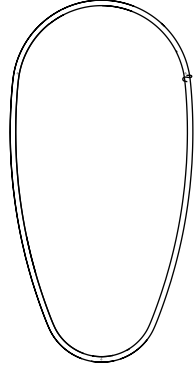

±1650 mm  
± 65"

circus oval S2000

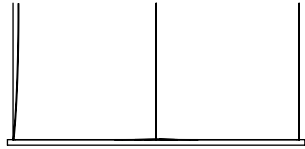
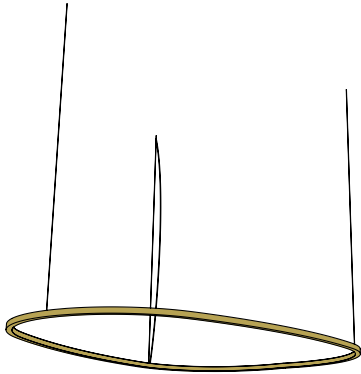
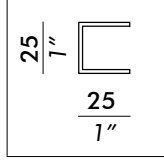

±1300 mm  
± 51"1/6

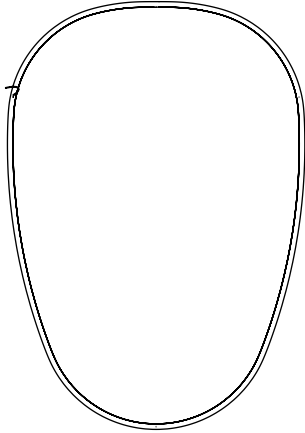

±2000 mm  
± 78" 3/4

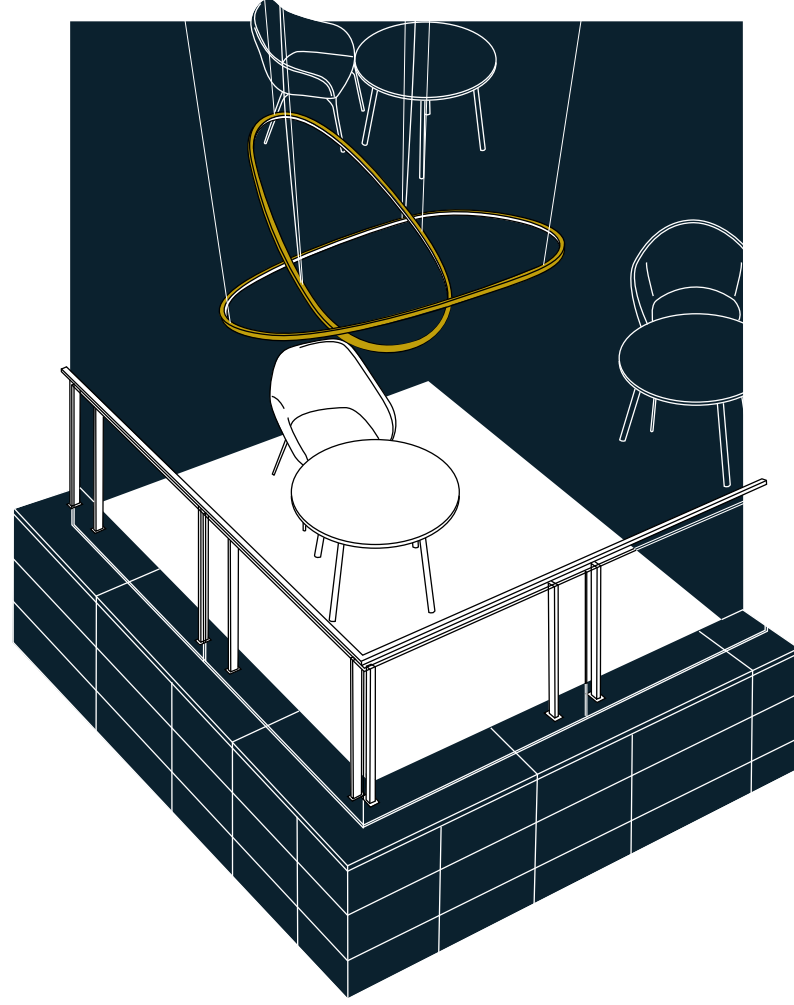



circus rectangular S1000x1500



circus square S1500x1500 + Acoustic panel

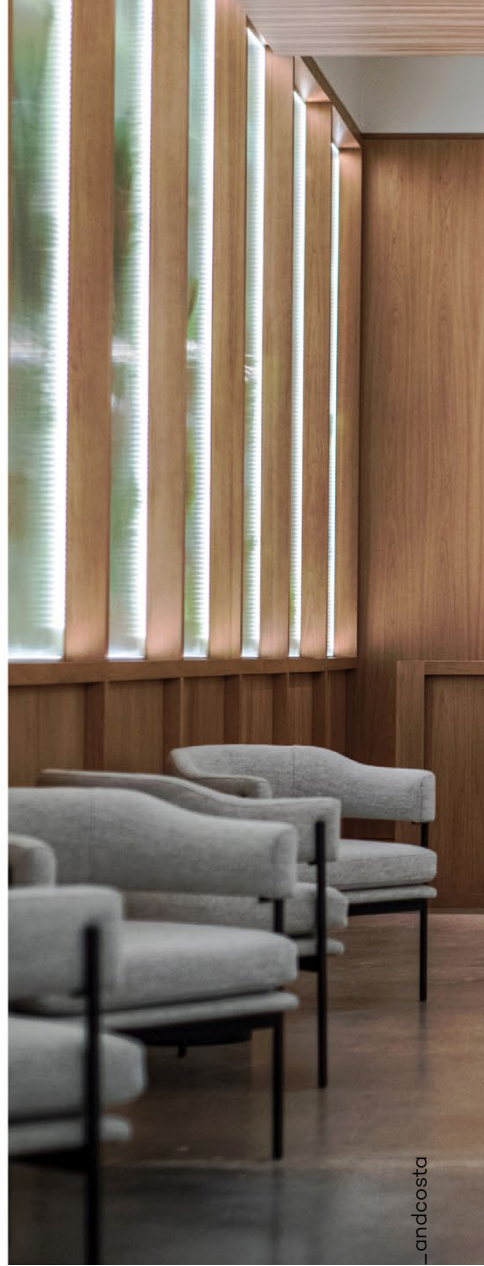





**circus rectangular S1000x1500**

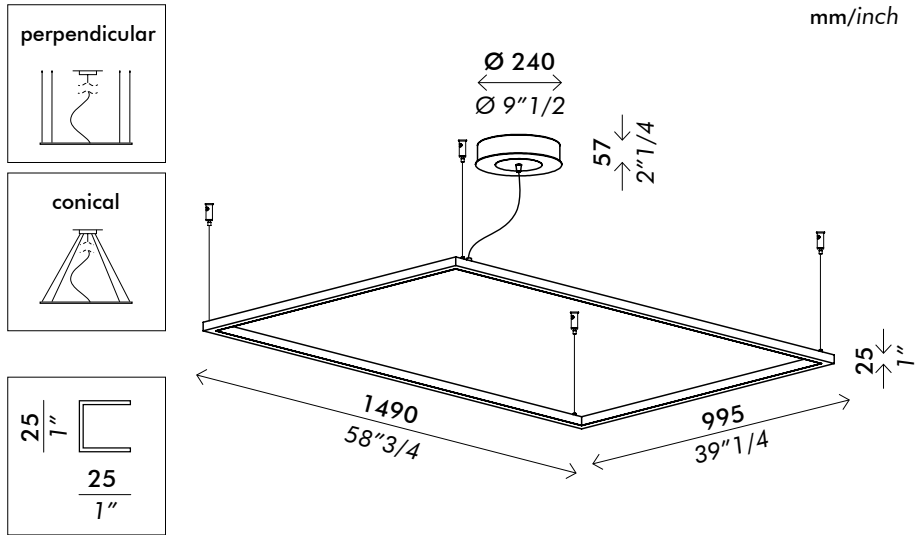

circus rectangular  
S1000x1500

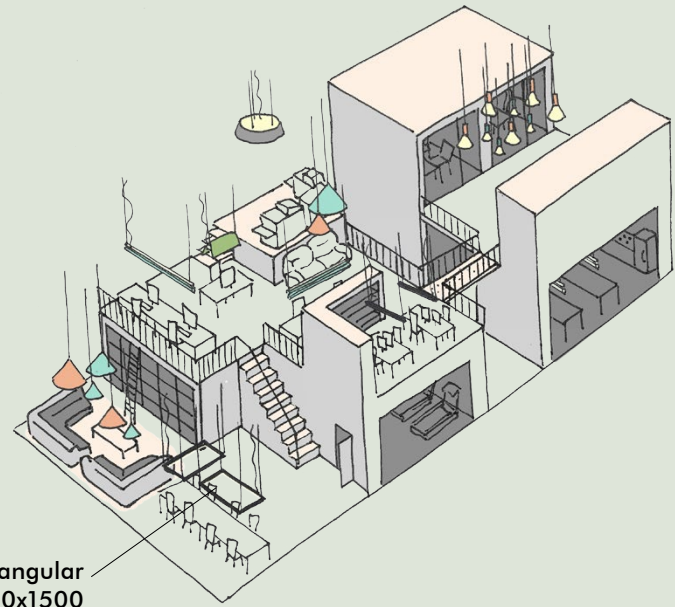

circus rectangular  
S1000x1500

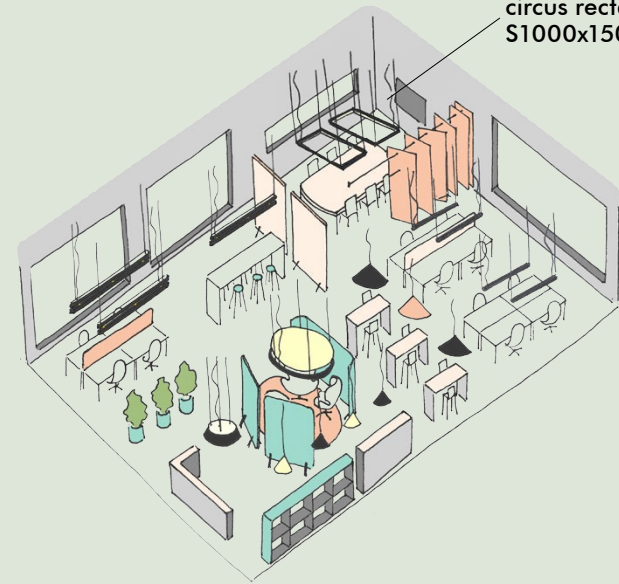



circus square S1500 - S1000





circus square S1500

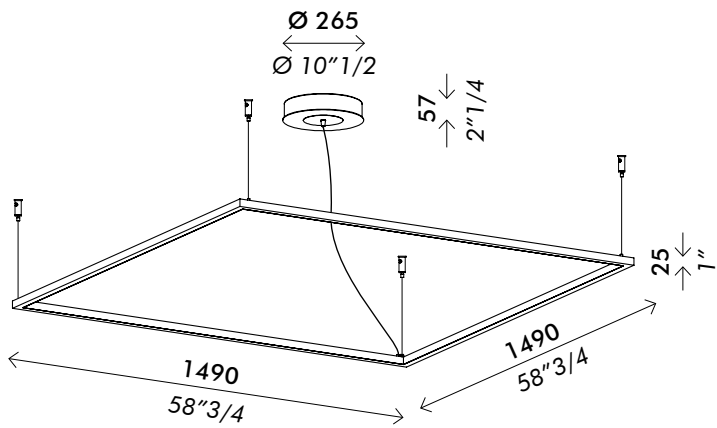
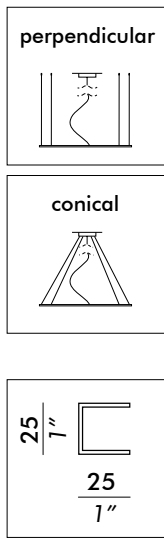

circus square S1000

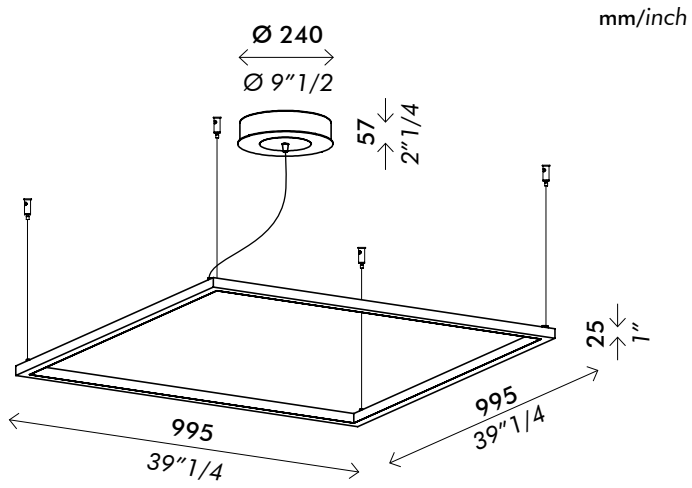
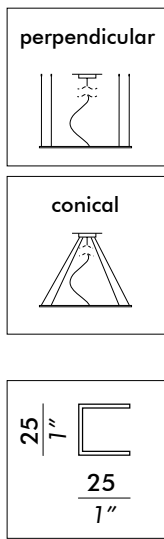

circus square S1500

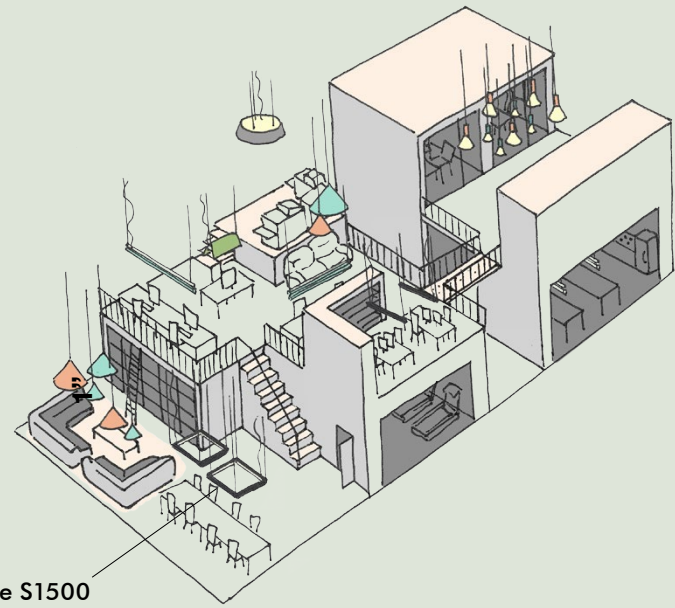

circus square S1000

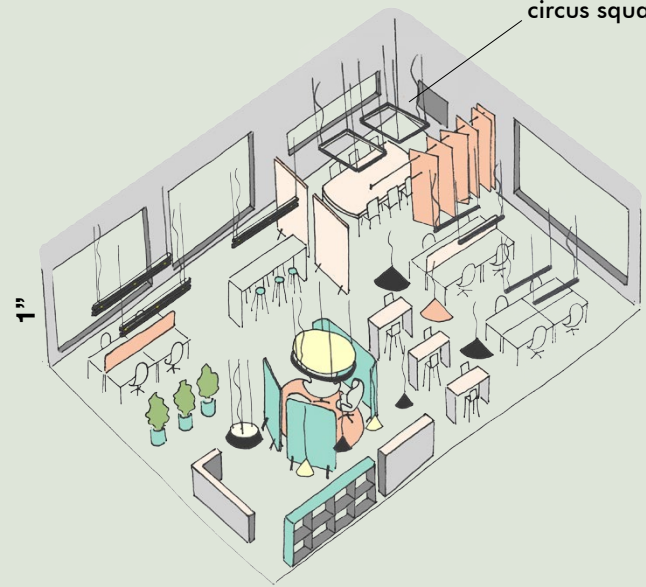



circus linear S1500





**circus linear S1500**

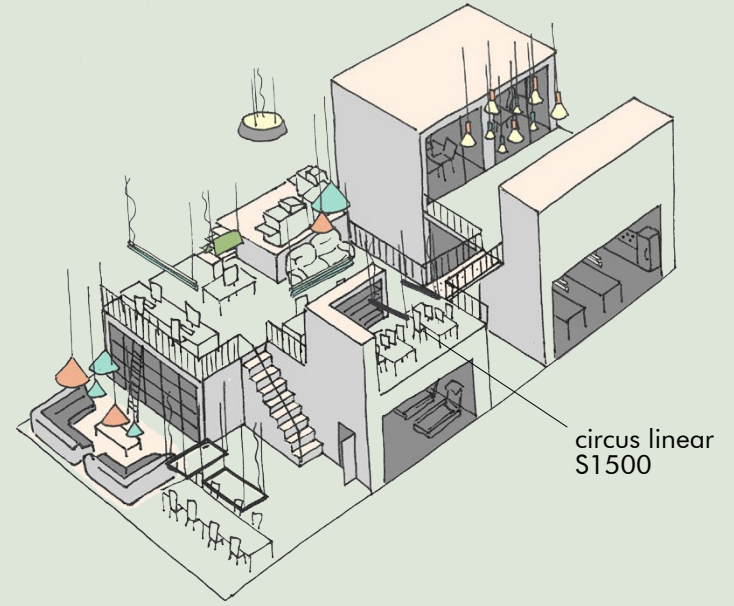
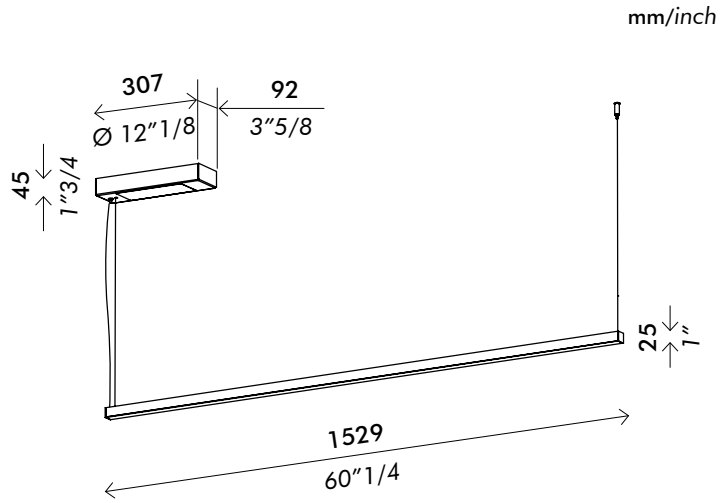
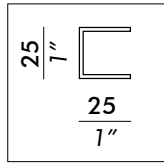
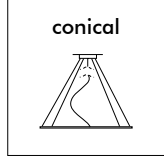
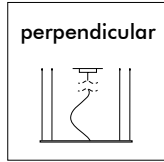

circus linear S1500



circus linear S1500

## circus acoustic panel

**Honeycomb polycarbonate acoustic panel with a removable upholstery in white, beige or black 100% polyester 3D fabric. Others available colours on request.**

A system for architectural lighting and acoustic control. The circus modular and suspended shapes represents ideal tools for variable sized showrooms, collective areas and workspaces. The collection includes three models with different sizes: **P500, P1000, P1500 and P2000.**

**DESIGN Carlo Zerbaro — 2015**



discover **CIRCUS ACOUSTIC PANEL** on our website 





circus round S1500  
+  
circus acoustic panel P1500  
+  
circus UPLIGHT

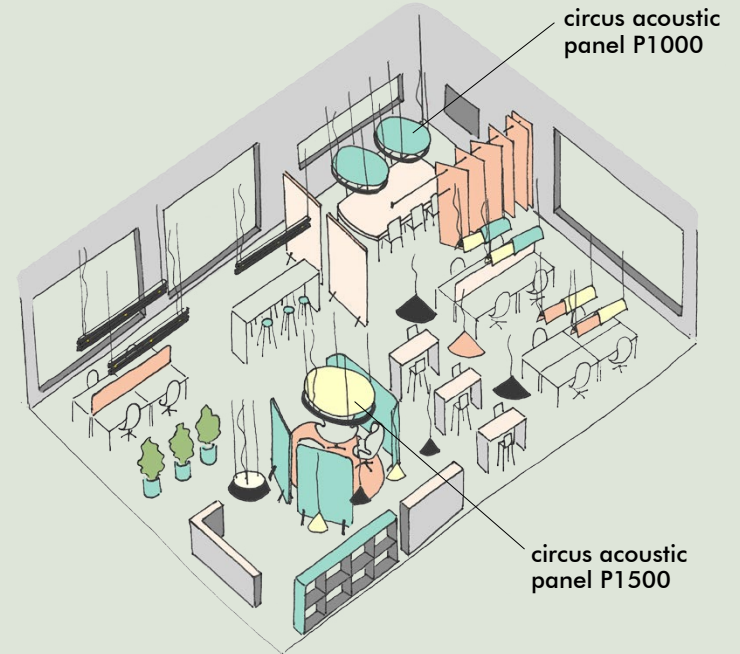

circus acoustic panel P1000

circus acoustic panel P1500

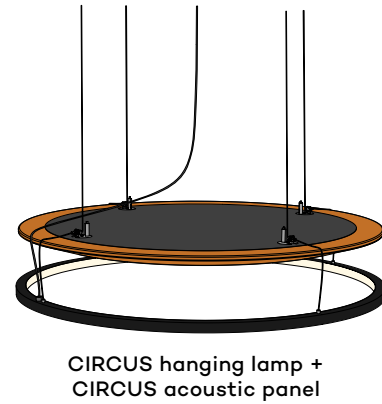
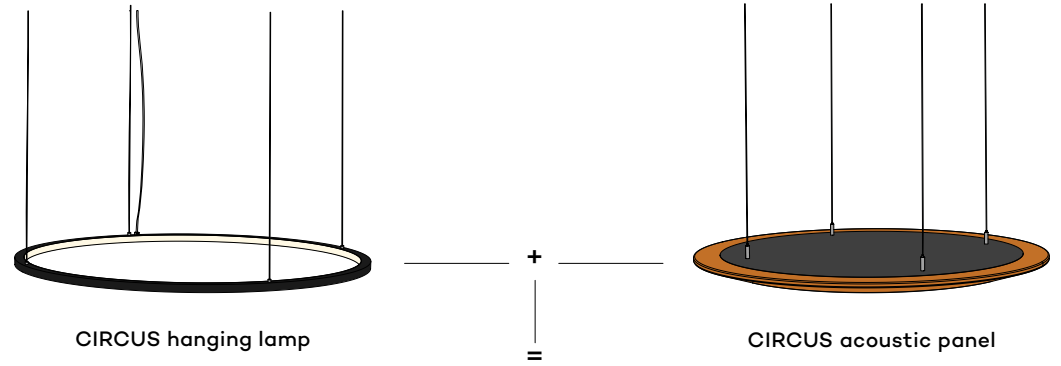

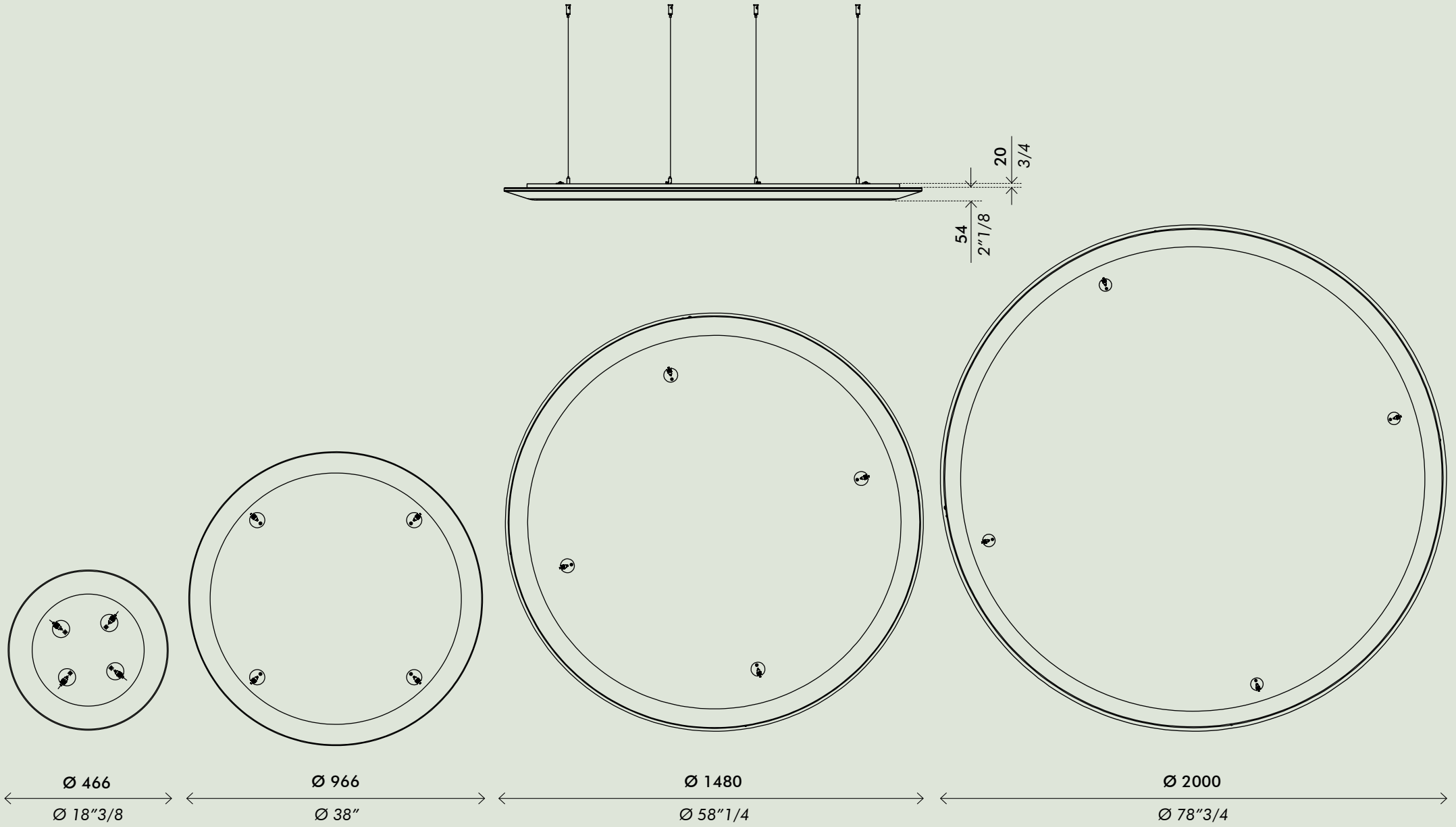

acoustic panel  
P500

acoustic panel  
P1000

acoustic panel  
P1500

acoustic panel  
P2000

acoustic panel P1000 square

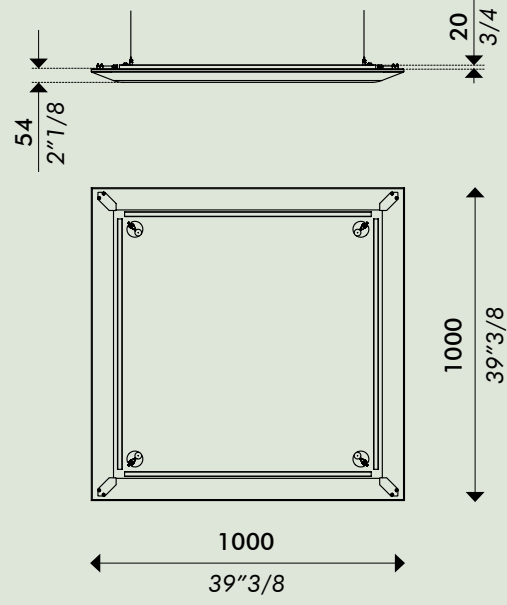

mm/inch

acoustic panel P1500 square

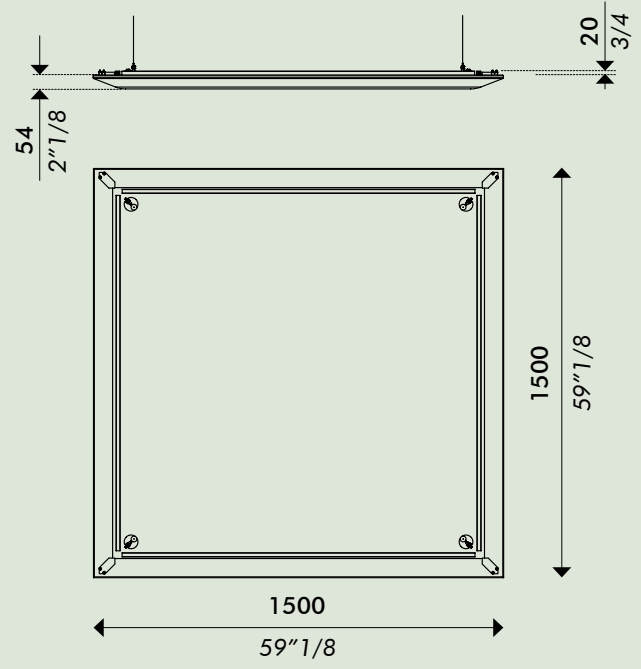

acoustic panel P1000x1500 rectangular

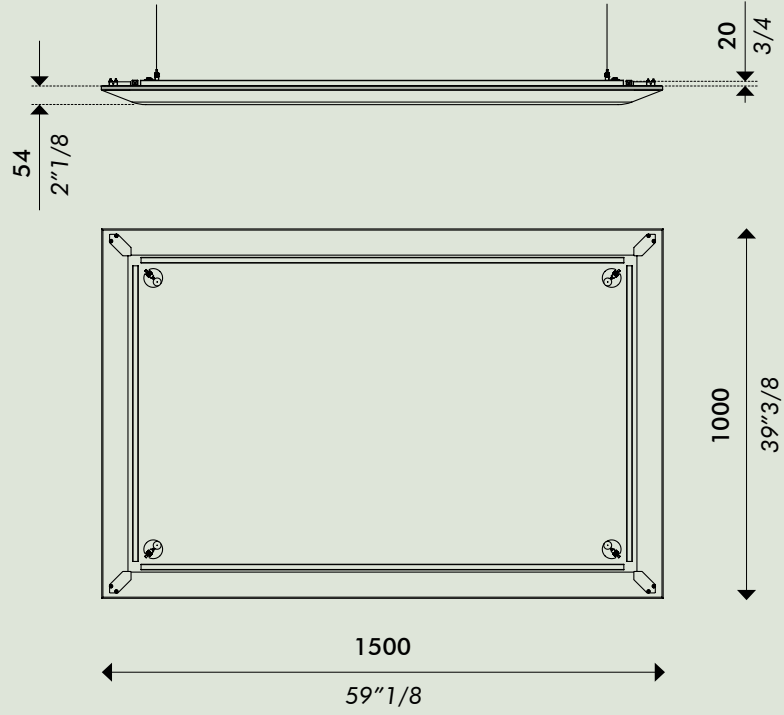

mm/inch

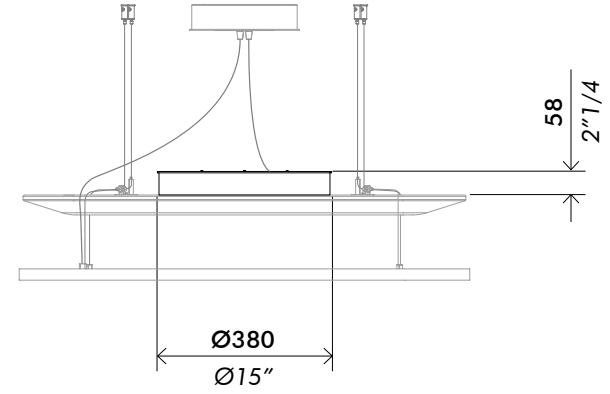
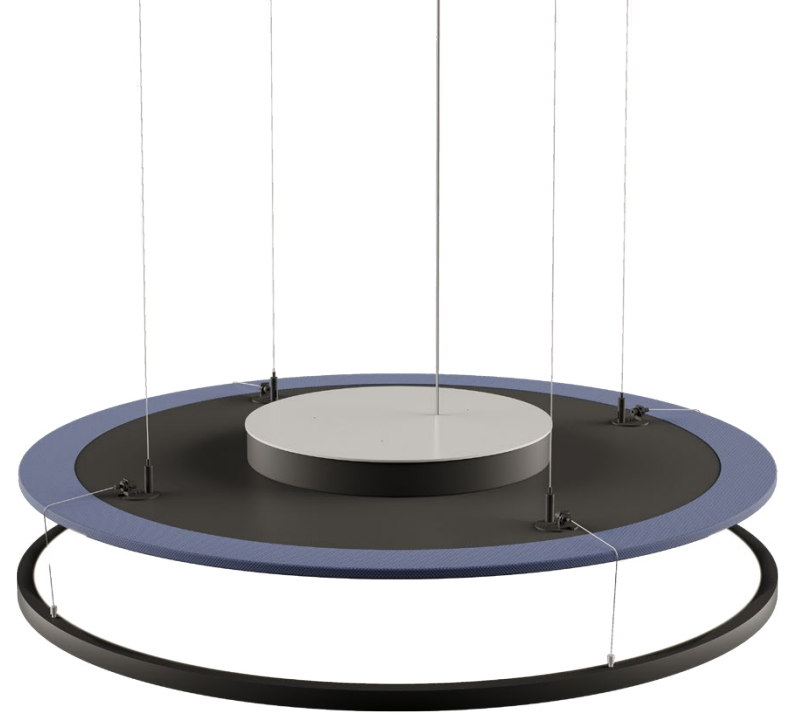

circus UPLIGHT



finish on request

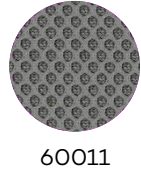

60011



60025



60165



61110



61129

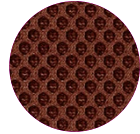

61130



62064



63034



64089



64199

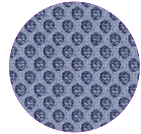

65078

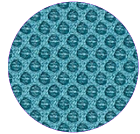

66063



66064

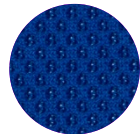

66120

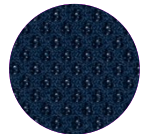

66123



66140

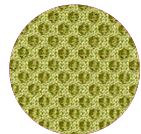

68056

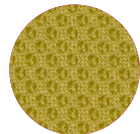

68108



68109

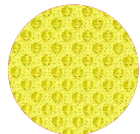

68137

standard finish



white  
60061



beige  
61128



black  
60999

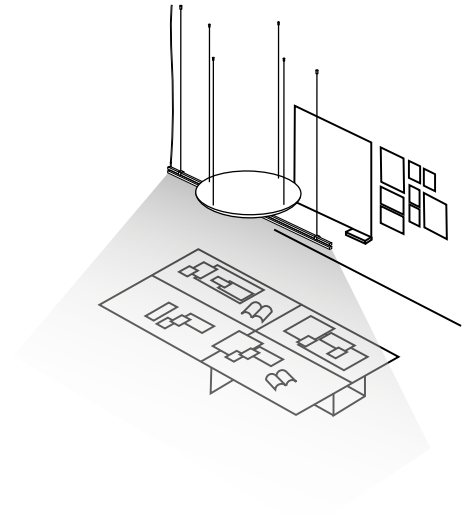
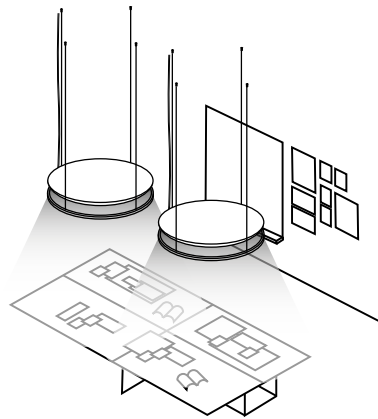
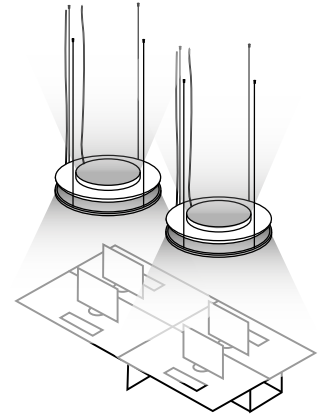
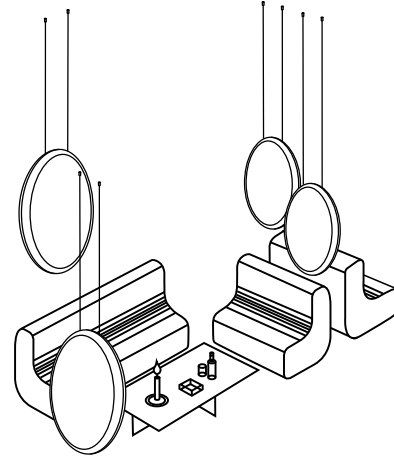

COLLECTION

**volare**

**ANDCOSTA**

# volare

**Hanging lamp with direct light and acoustic control. Longitudinal lighting body with aluminium structure matt white, black or brass coated. PMMA prismatic diffuser easily-removable for an easy maintenance. Overlapping sound absorbing panels with removable upholstery in white, black or beige 3D fabric. Others available colours on request. LED module.**

With its dynamic design it defines the space by personalizing the environment with **chromatic overlays** available in different shades.

**DESIGN AndCosta R&D ——— 2019**



[discover VOLARE on our website](#) 



volare S1304



volare S1780

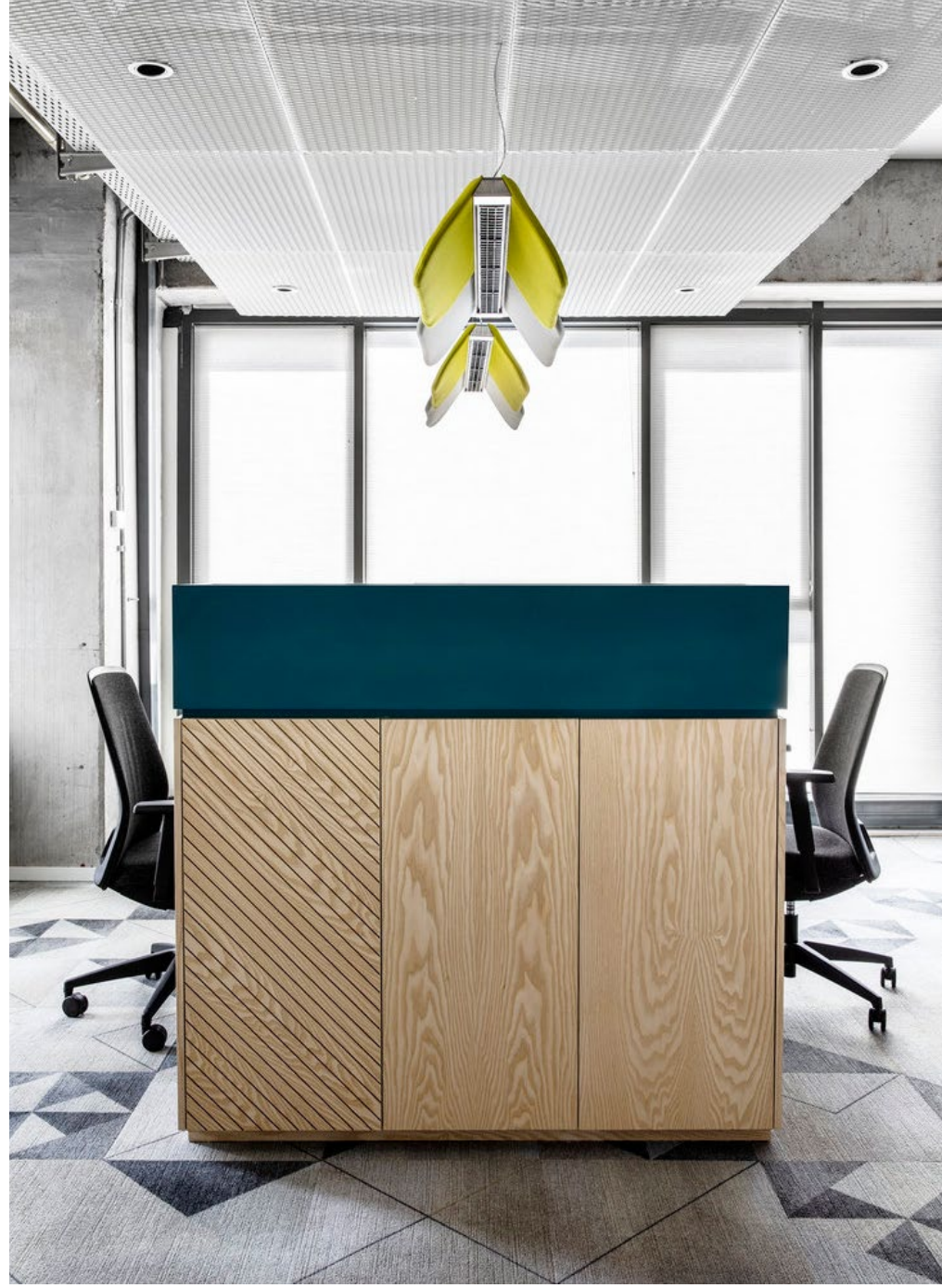

volare S1780

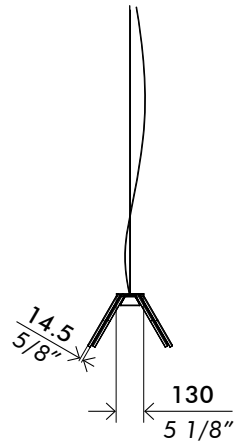
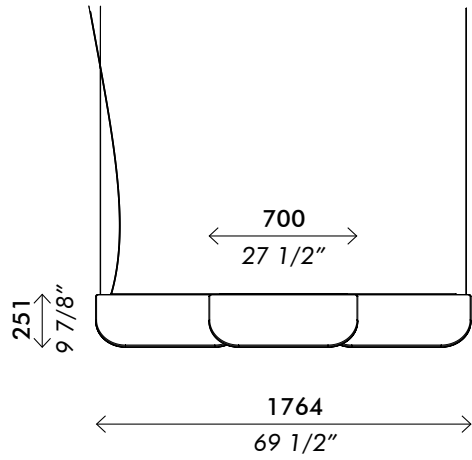

mm/inch

volare S1304

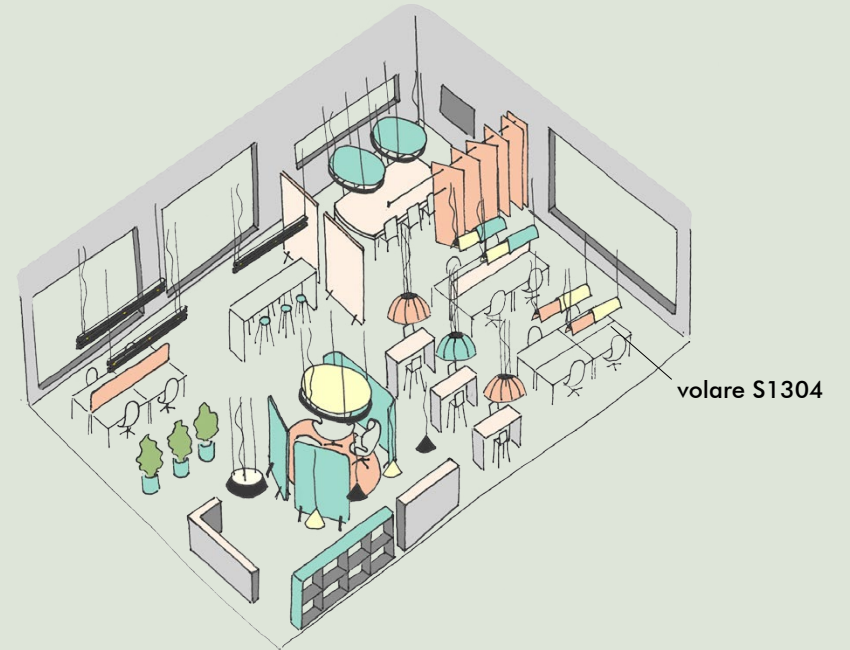
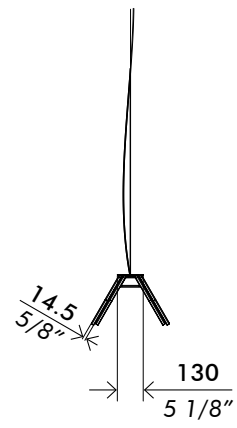
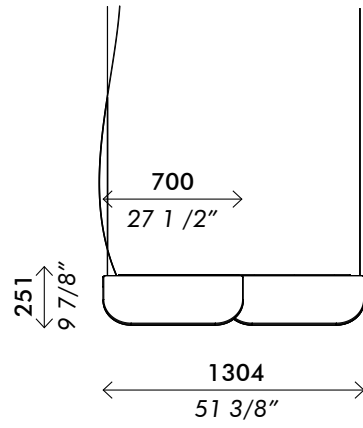

COLLECTION

**cyl**

**ANDCOSTA**



# cyl

**Spotlight for accent lighting  
Ø 45, 60, 75 mm with canopy,  
mini canopy, or designed for low  
voltage multisystem track (48V).**

**Maximum flexibility in home,  
retail, hospitality and  
museum environments.**

**Integrated driver, available control  
versions On/Off, Dali and 0-1/10V.**

**Aluminium structure white,  
black or brass coated.**

**Latest generation COB LED light  
source. New precision PMMA  
lenses, available in 3 beam angles.**

**Black anti-glare ring.**

The new range of  
spotlights designed on  
the **low-voltage  
multisystem track  
system**, for ceiling and  
wall installation,  
to create the perfect  
**accent lighting** for  
home, retail, hospitality,  
and museum  
environments.

Cyl dialogues with the  
architecture through  
its **various versions**, with  
**options of power, light  
output, and narrow,  
medium, and wide beam  
optics.**

**DESIGN AndCosta Team — 2022  
+ Stefano Azzolin**





cyl Ø 45, 60, 75 mm 100-240V

**class III**

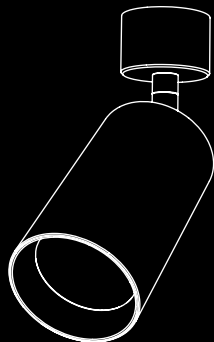

**100-240V**

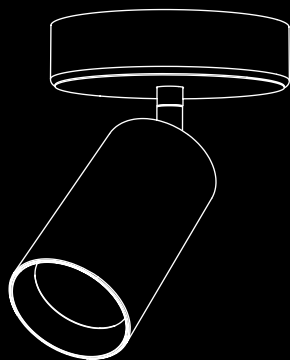

**track 48V**

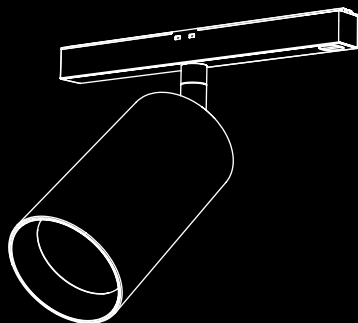

CYL class III Ø 60 mm





CYL track 48V Ø 45 mm

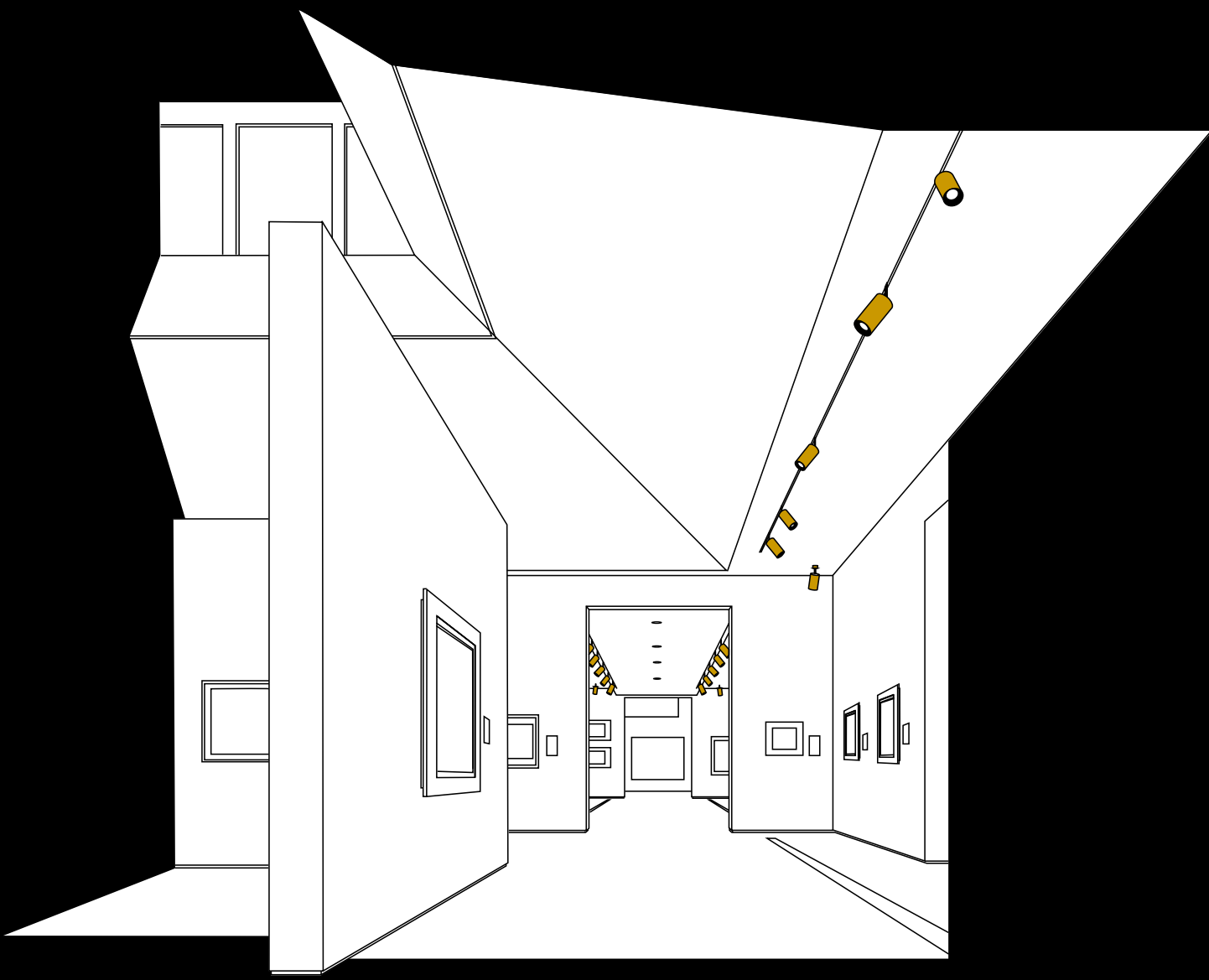

mm/inch

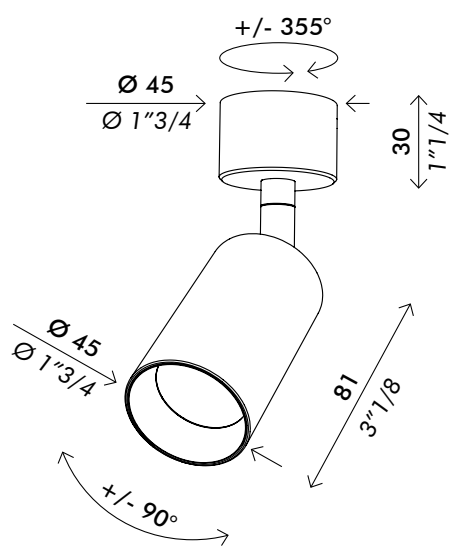
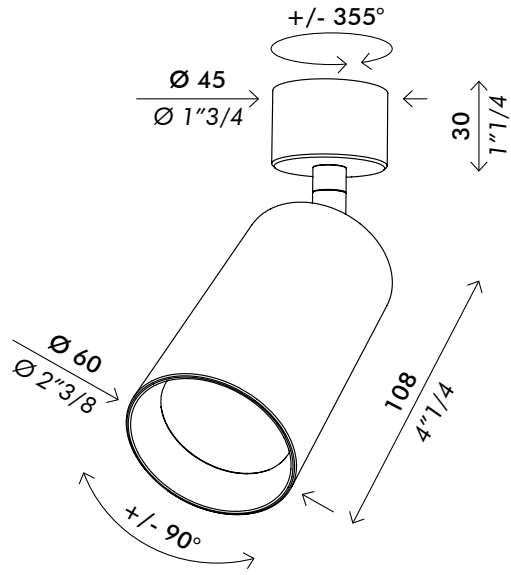
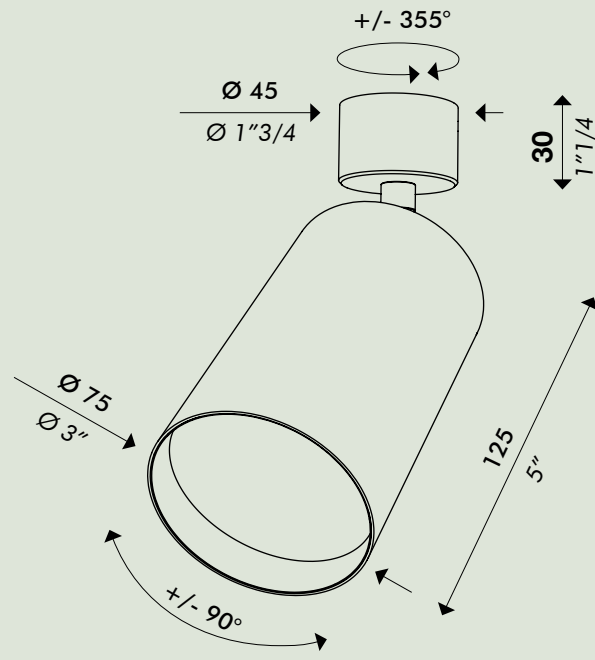
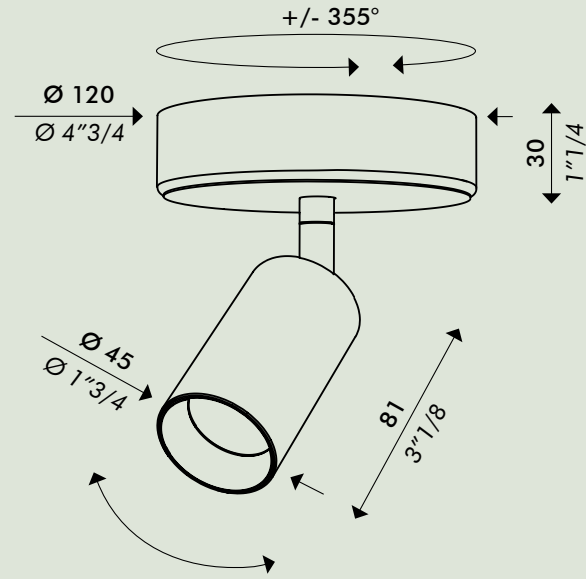
cyl class III Ø 45cyl class III Ø 60cyl class III Ø 75cyl 100-240V Ø 45

mm/inch

cyl 100-240V Ø 60

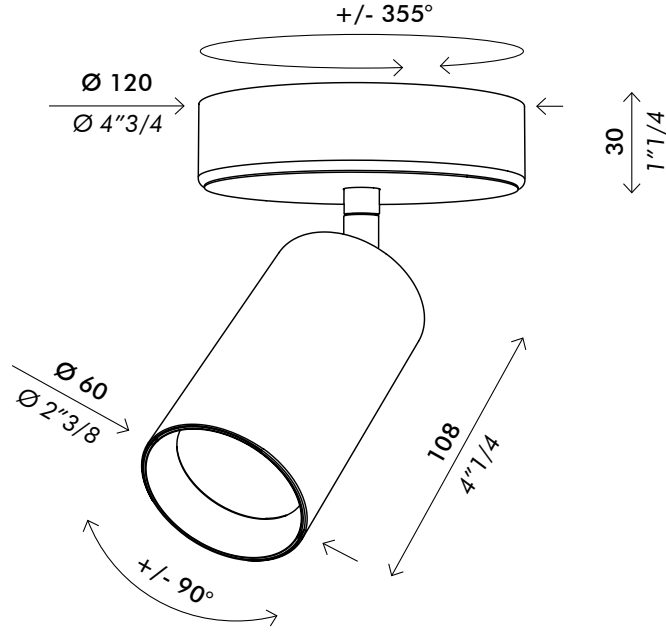

cyl 100-240V Ø 75

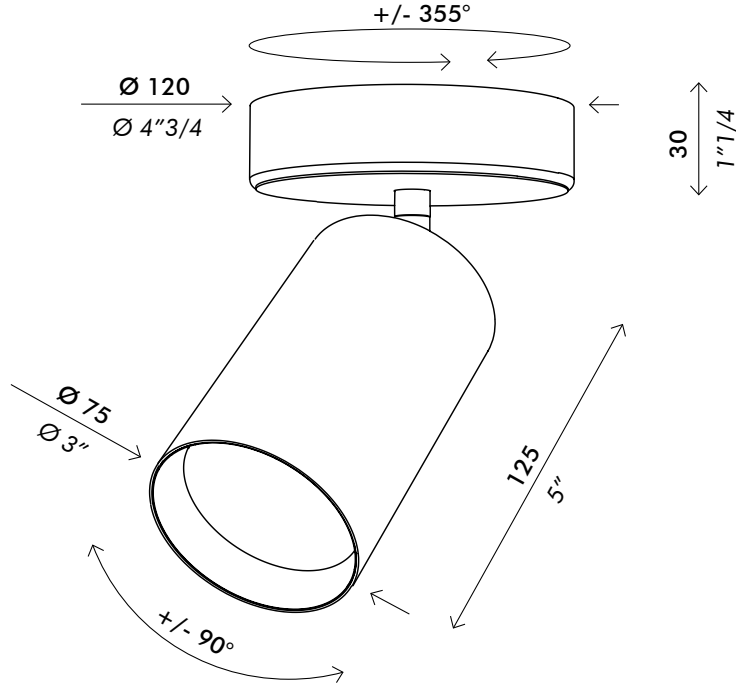

cyl track 48V Ø 45

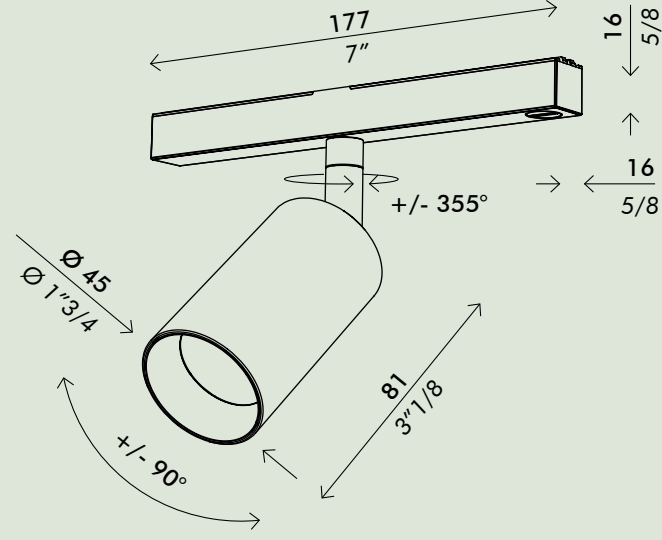

cyl track 48V Ø 60

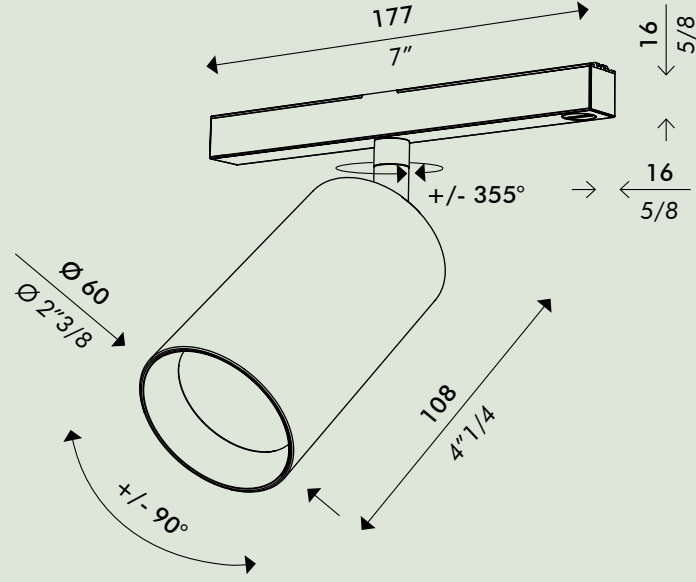



cyl track 48V Ø 75

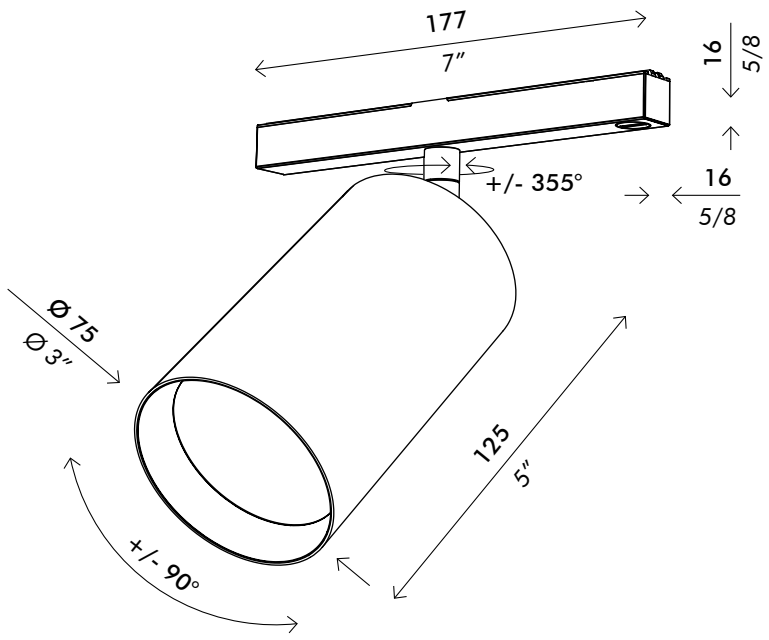

mm/inch

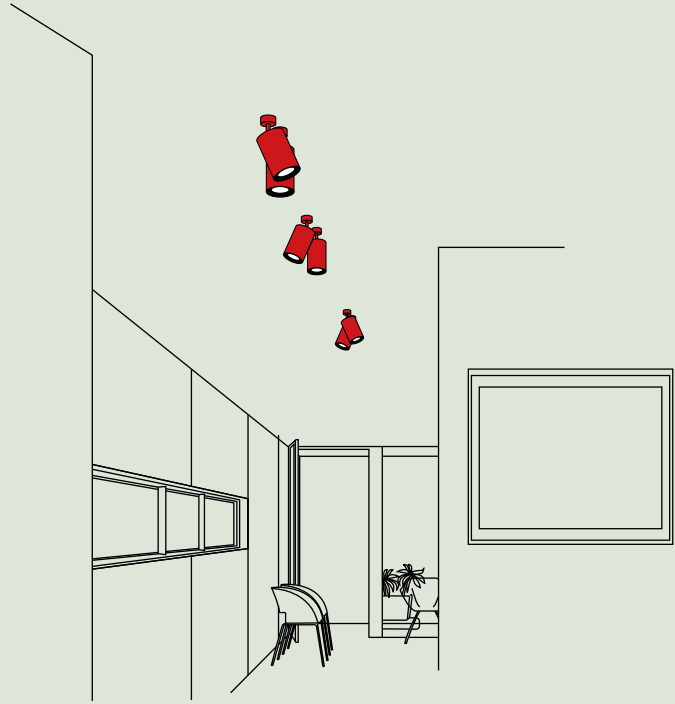

COLLECTION

**daytona**

**ANDCOSTA**

# daytona

Lighting modular system with direct light, hanging and ceiling lamps connectable together or available in a standalone configuration. Aluminium structure white, black or brass coated. Linear profiles with opal polycarbonate or darklight optic diffuser, round structures with opal polycarbonate diffuser. Strip LED on polycarbonate diffuser or LED module on darklight optic diffuser.

## Available configurations:

### - Linear profiles:

570, 860, 1140, 1420, 1700 mm;

### - Bent semicircular structures for round configurations:

Ø 600, 900, 1270, 1800 mm;

### - Oval configurations:

600x1200, 900x2000, 900x2600, 1270x2100, 1270x3000, 1800x3500 mm.





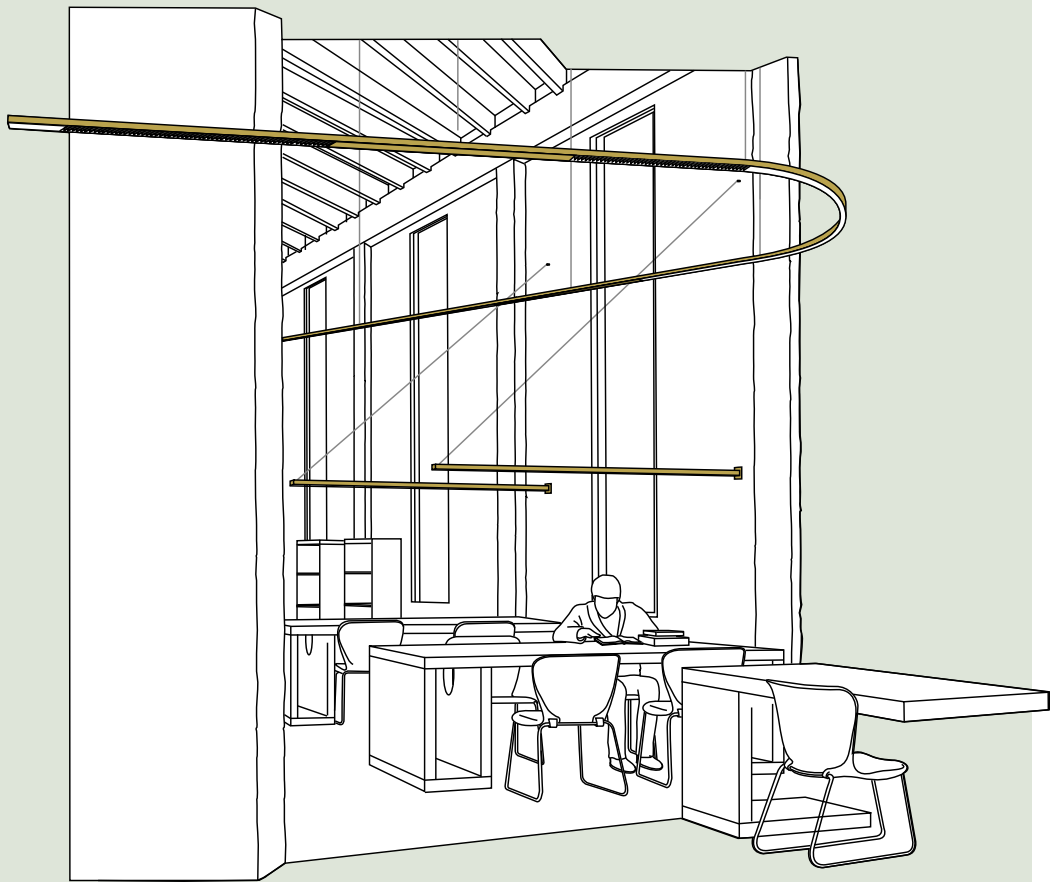

### Configuration examples

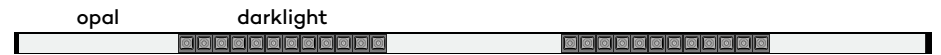
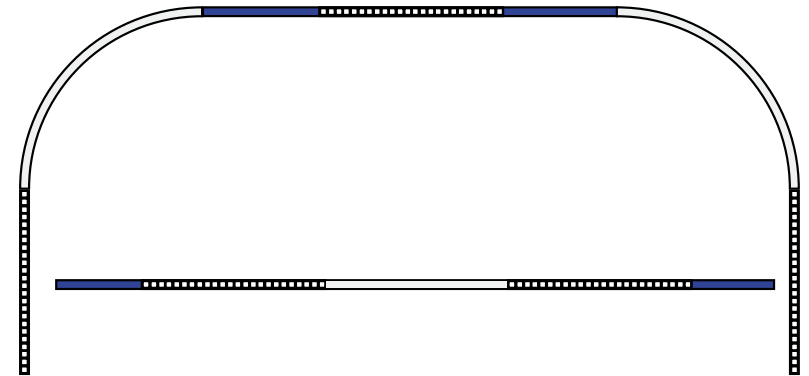
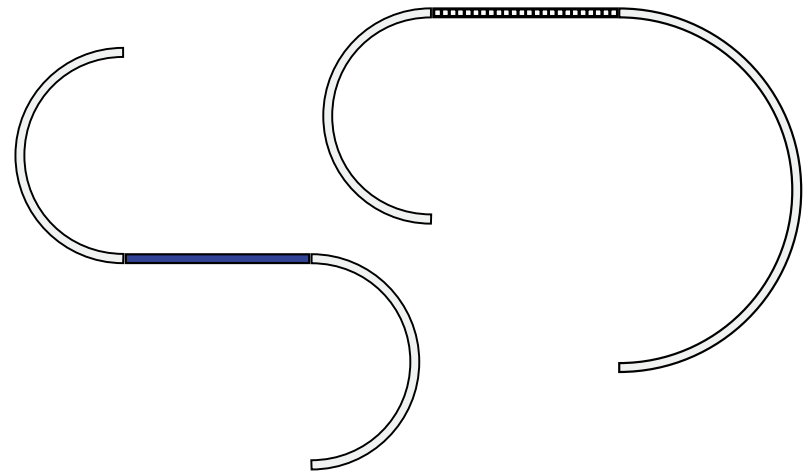

daytona Linear S570, S860 and S1140



mm/inch

available dimensions:

570 / 22"3/4

860 / 33"3/4

1140 / 44"7/8

1420 / 55"3/4

1700 / 67"

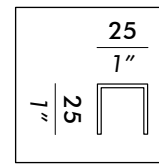
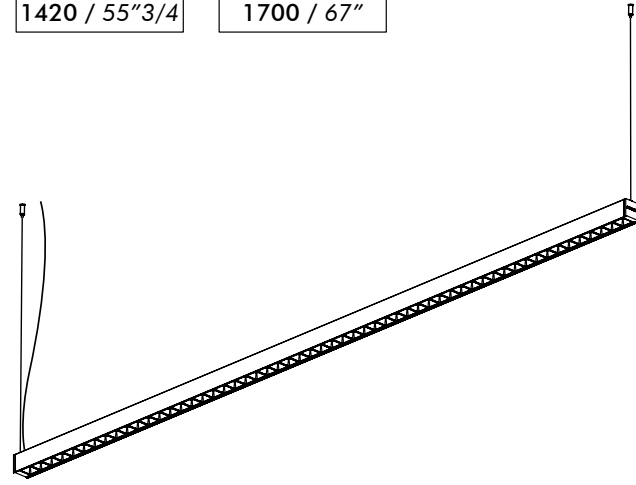

dark light diffuser

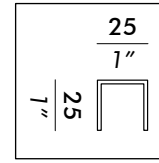
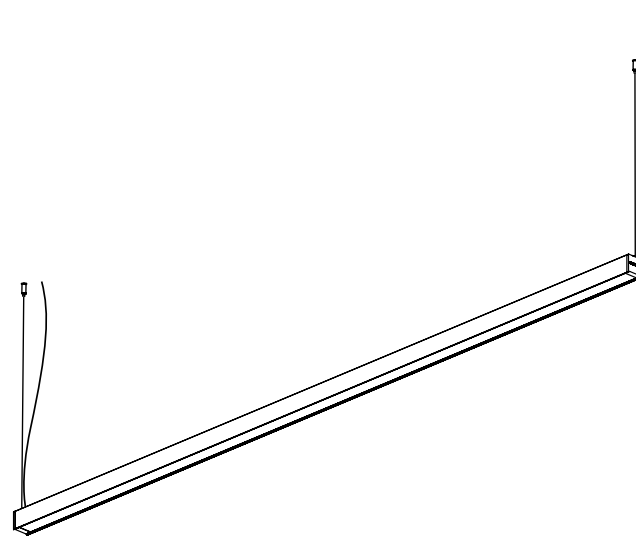

opal diffuser

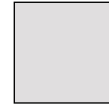

daytona LINEAR hanging lamp  
DARK LIGHT diffuser

daytona LINEAR hanging lamp  
OPAL diffuser

daytona Round S600 and S1270



mm/inch

available dimensions:

Ø 600 / 23"5/8

Ø 900 / 35"1/2

Ø 1270 / 50"

Ø 1800 / 70"7/8

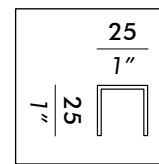
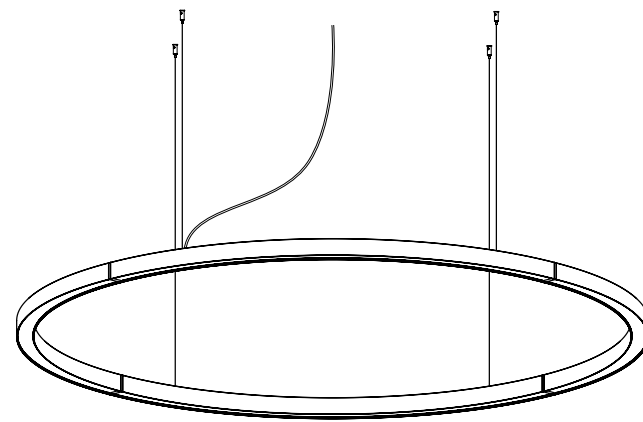

opal diffuser



daytona ROUND hanging lamp  
only with OPAL diffuser



daytona Oval S600x1200 and S1270x2100



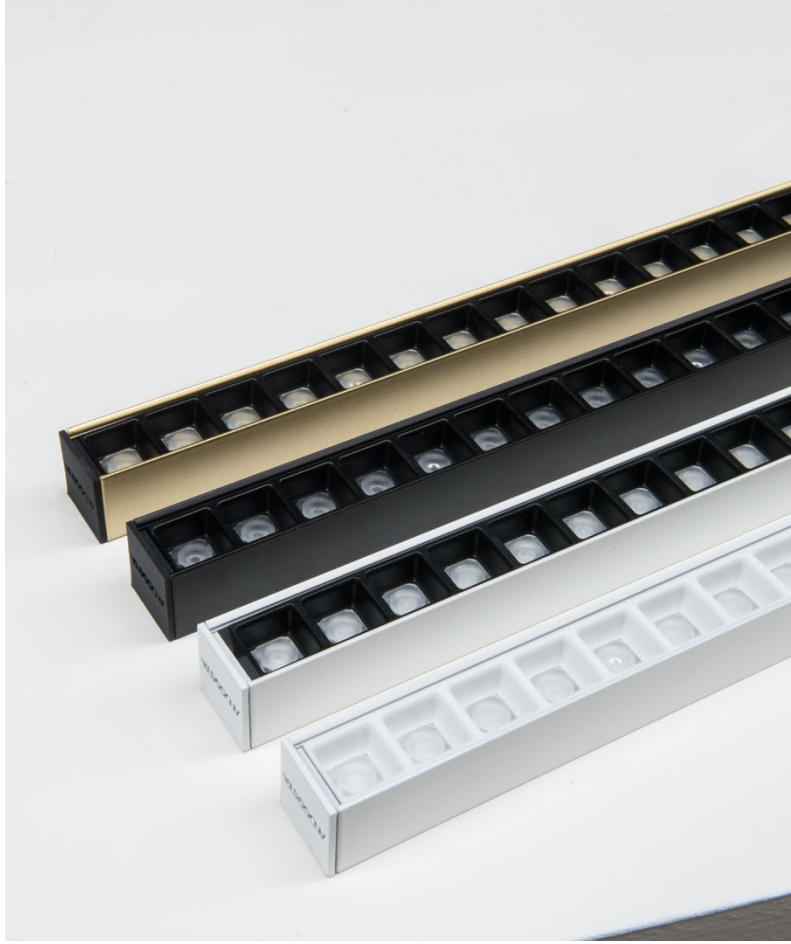

mm/inch

available dimensions:

600x1200 /  
23"5/8x46"1/8

900x2000 /  
36"5/8x81"1/2

900x2500 /  
36"5/8x103"3/8

1270x2100 /  
50"1/4x83"3/4

1270x3000 /  
50"1/4x117"

1800x3500 /  
72"1/8x138"3/4

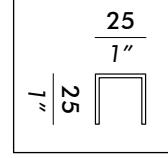

dark light diffuser

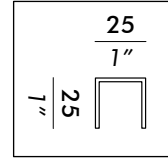
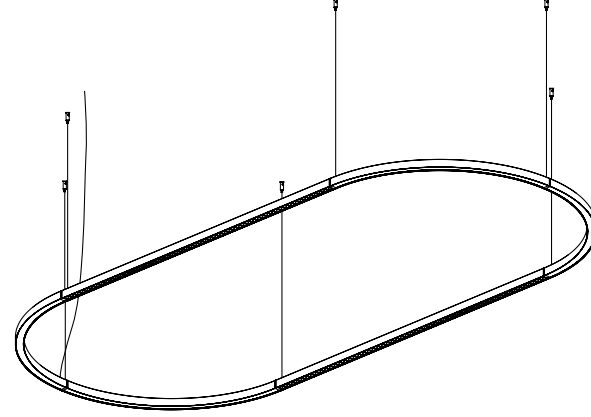

opal diffuser

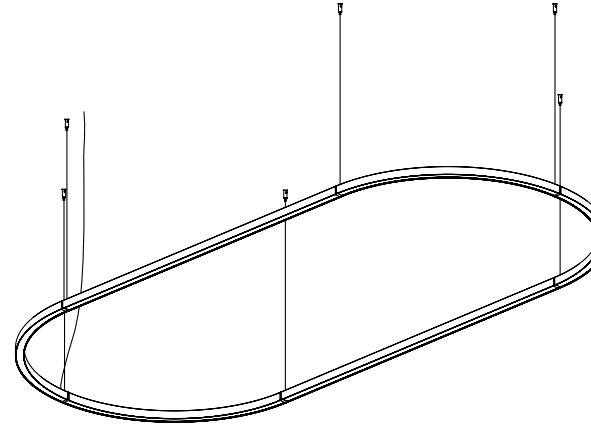

daytona OVAL hanging lamp  
OPAL diffuser

daytona OVAL hanging lamp  
DARK LIGHT diffuser

mm/inch

daytona LINEAR ceiling lamp  
OPAL diffuser

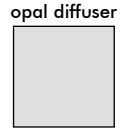
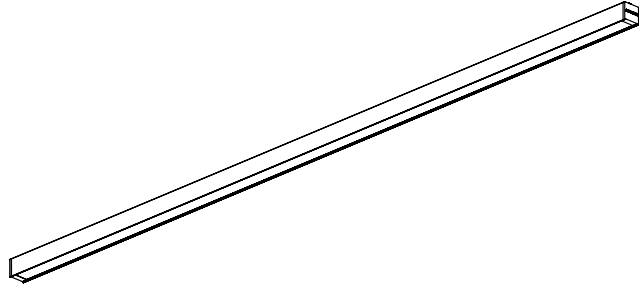

daytona LINEAR ceiling lamp  
DARK LIGHT diffuser

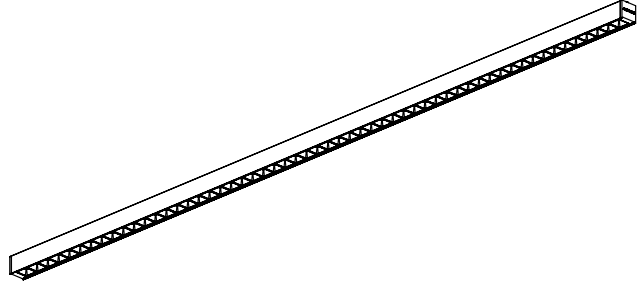

available dimensions:

570 / 22"3/4

860 / 33"3/4

1140 / 44"7/8

1420 / 55"3/4

1700 / 67"

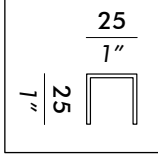

available dimensions:

Ø 600 / 23"5/8

Ø 900 / 35"1/2

Ø 1270 / 50"

Ø 1800 / 70"7/8

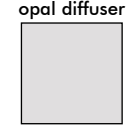
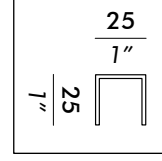
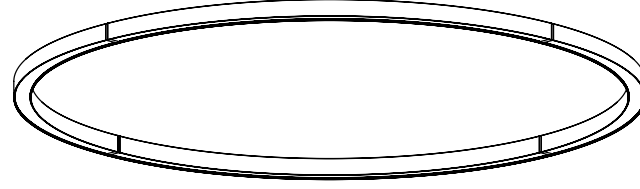

daytona ROUND ceiling lamp  
only with OPAL diffuser

mm/inch

daytona OVAL ceiling lamp  
DARK LIGHT diffuser

available dimensions:

600x1200 /  
23"5/8x46"1/8

900x2000 /  
36"5/8x81"1/2

900x2500 /  
36"5/8x103"3/8

1270x2100 /  
50"1/4x83"3/4

1270x3000 /  
50"1/4x117"

1800x3500 /  
72"1/8x138"3/4

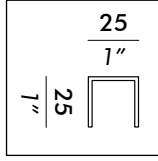

dark light diffuser

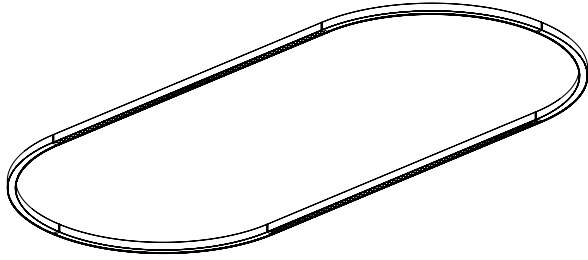

daytona OVAL ceiling lamp  
OPAL diffuser

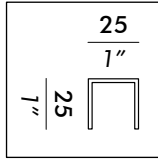

opal diffuser

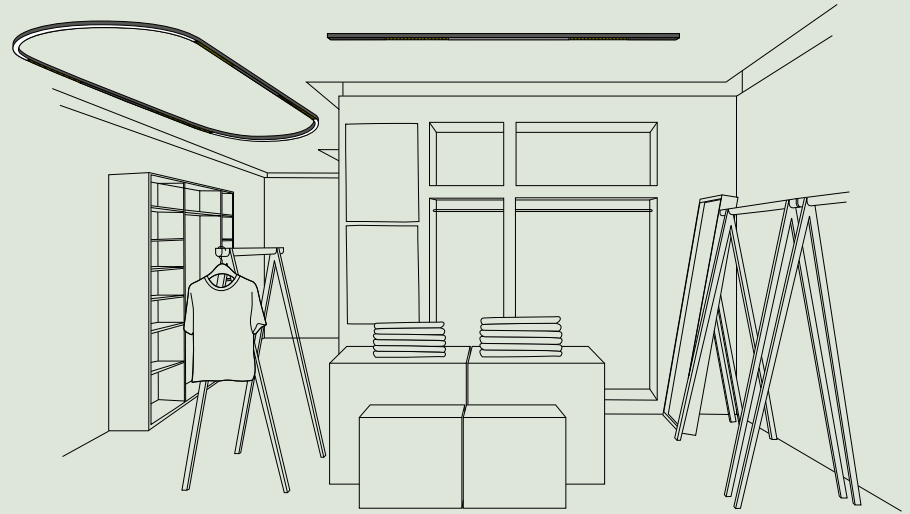
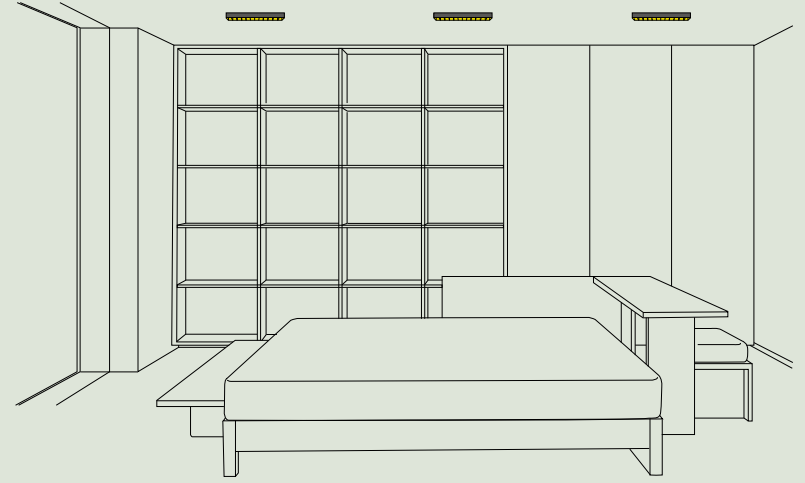
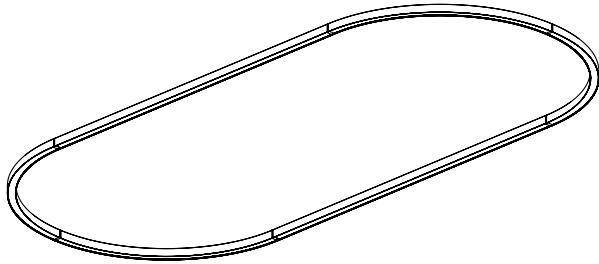

COLLECTION

**duplo**

**ANDCOSTA**

# duplo

**Hanging lamp with direct and indirect light.**  
**Aluminium structure embossed white or black or matt brass coated.**  
**Opal polycarbonate or transparent prismatic diffuser.**  
**Metal ceiling canopy embossed white or black or matt brass coated. Strip LED.**  
**Separate switch direct/indirect.**

Where the volume abdicates in favor of the essentiality of the sign that releases light.  
A system for **architectural lighting** that celebrates the absence-essence of substance: **not object but vector of illumination.**

**DESIGN Carlo Zerbaro — 2018**



discover DUPLO on our website 







mod. S1180

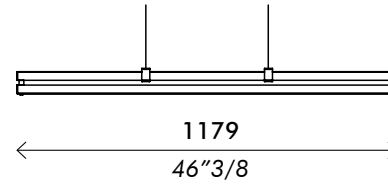

mod. S1980

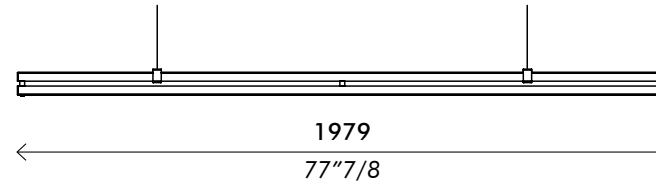

mod. S2875

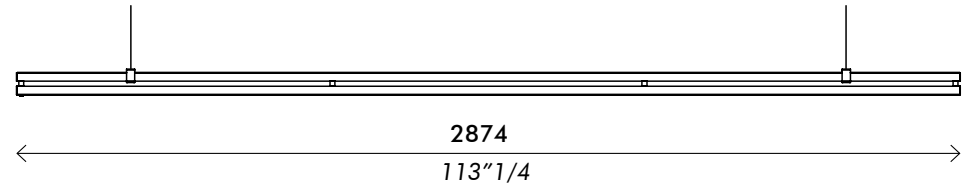

mm/inch





mm/inch

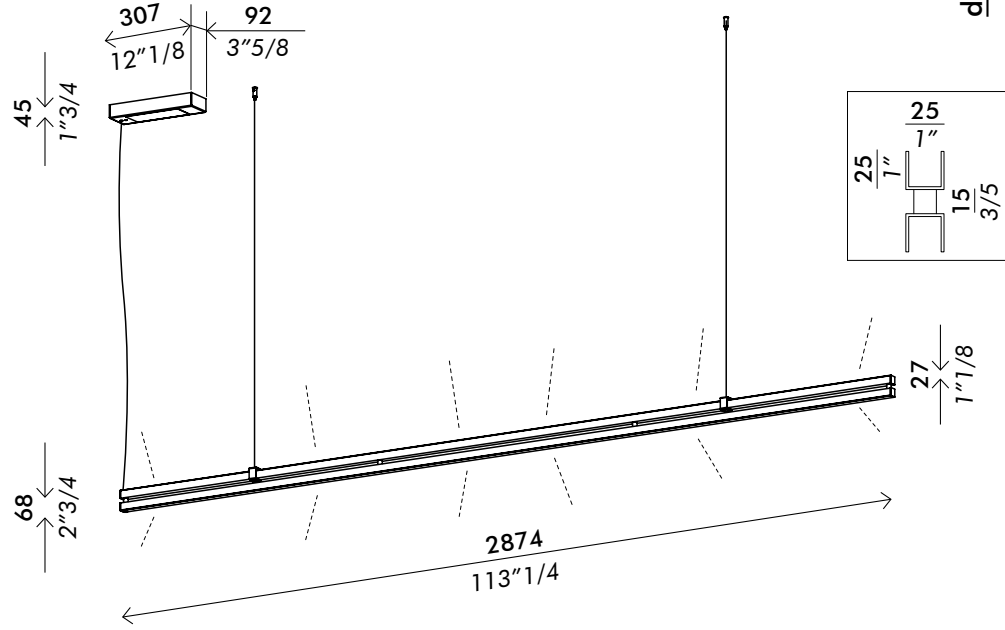

duplo S1980

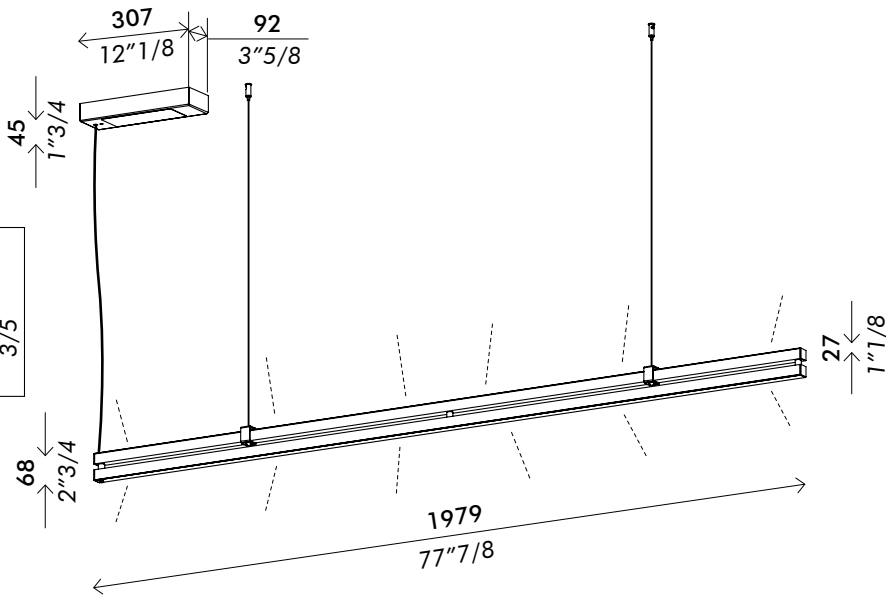
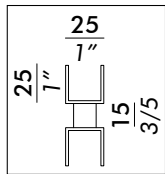

mm/inch

duplo S1180

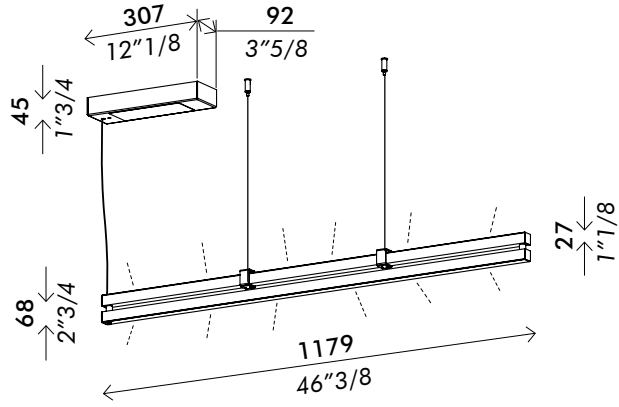
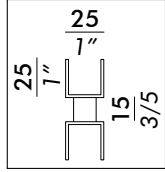

duplo S2875

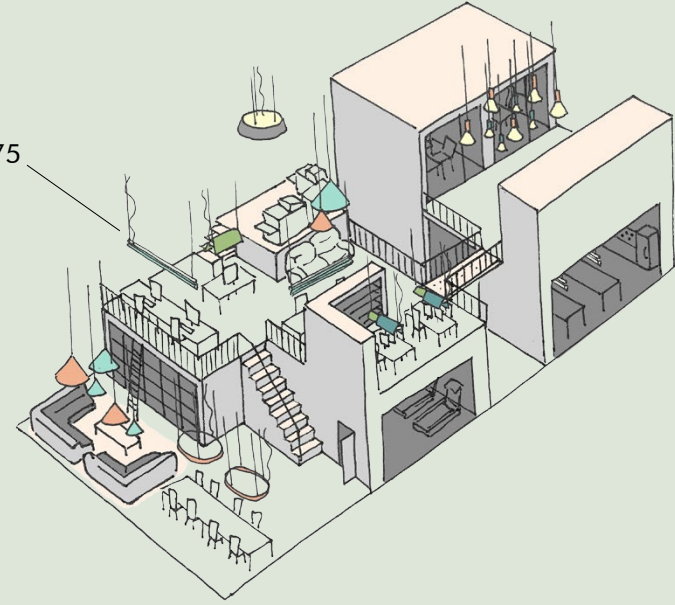

duplo S2875



COLLECTION

**luna**

**ANDCOSTA**

# luna

**Hanging lamps with diffused direct or direct and indirect light. Aluminium structure matt white, black or brass coated. Opal membrane diffuser. Metal ceiling canopy matt white, black or brass coated. Strip LED.**

As an homage to the pale shape of the moon, **Luna** is a charming and mysterious lighting object with an **high-poetic profile.** Available models: **vertical and horizontal hanging, ceiling, wall and floor standing.** Available in three sizes, **S430, S900** and **S1250**, this lamp is the perfect solutions for cluster compositions in wide spaces.

**Carlo Zerbaro — 2021**



luna S900 and S1250 vertical





luna S430, S900 and S1250 horizontal



mm/inch

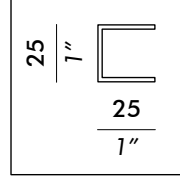
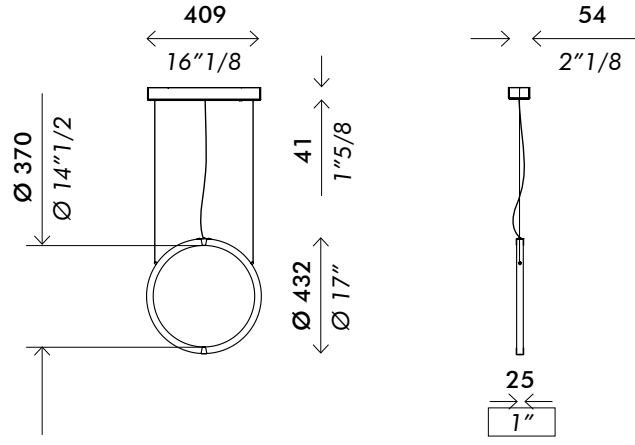

luna S430 vertical

luna S900 vertical

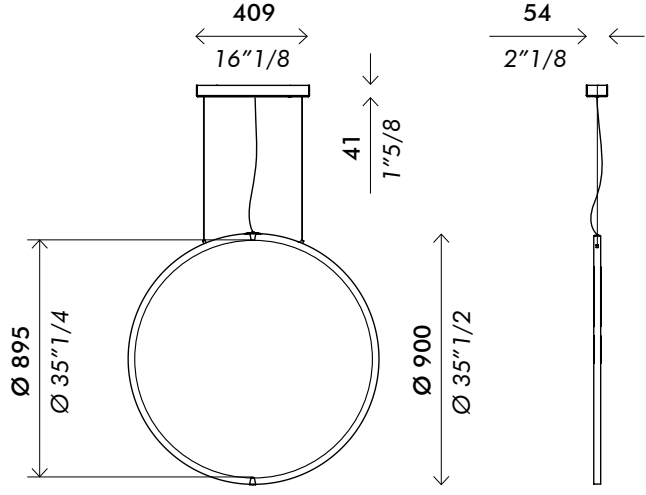
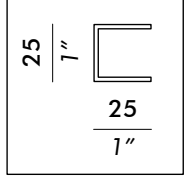

mm/inch

luna S1250 vertical

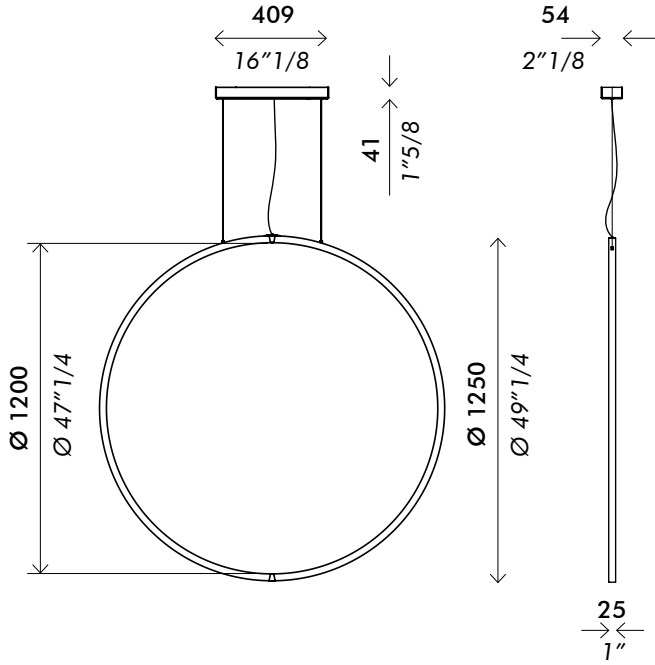
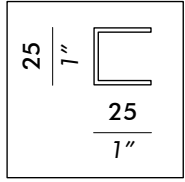

luna S900 and S1250 vertical





luna S1250 horizontal



mm/inch

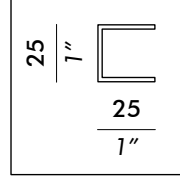
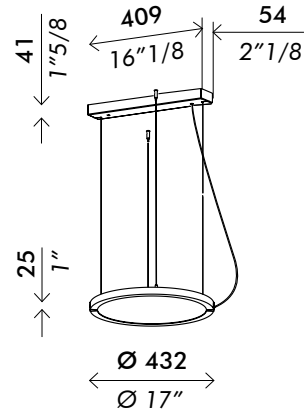

Luna S430 horizontal

mm/inch

luna S1250 horizontal

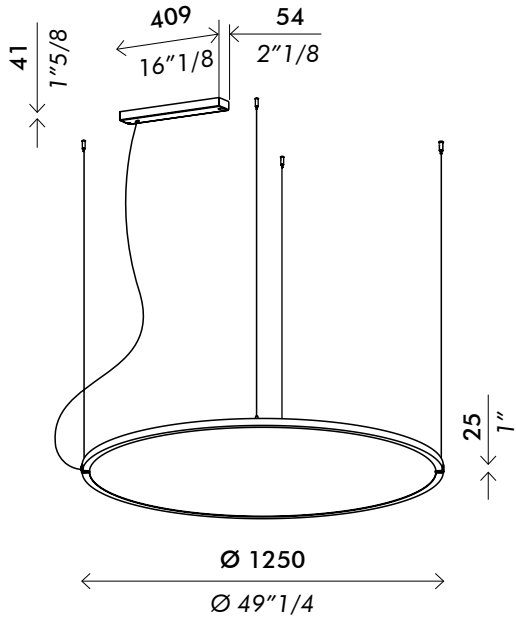
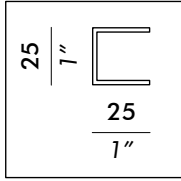

luna S900 horizontal

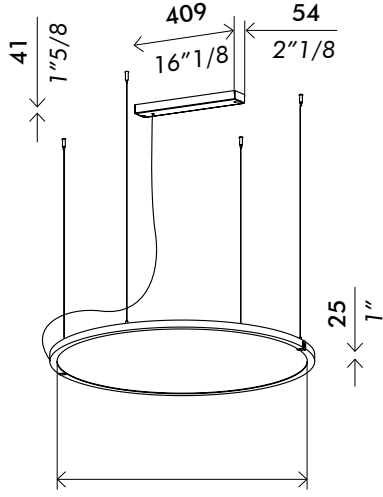
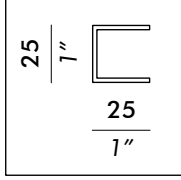

luna C900

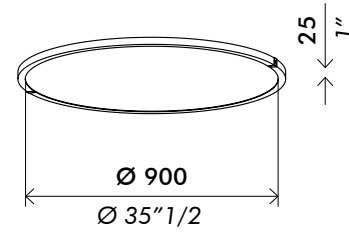
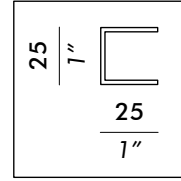

luna C430

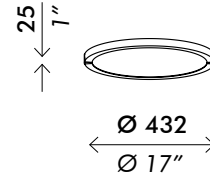
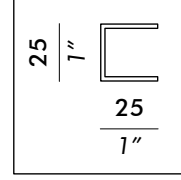

luna C1250

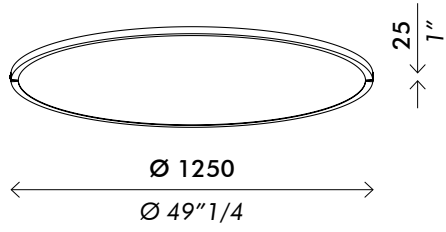
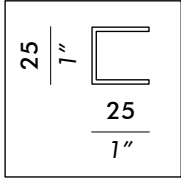

mm/inch





luna F1250 + F900

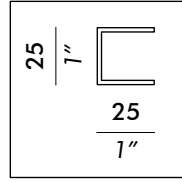
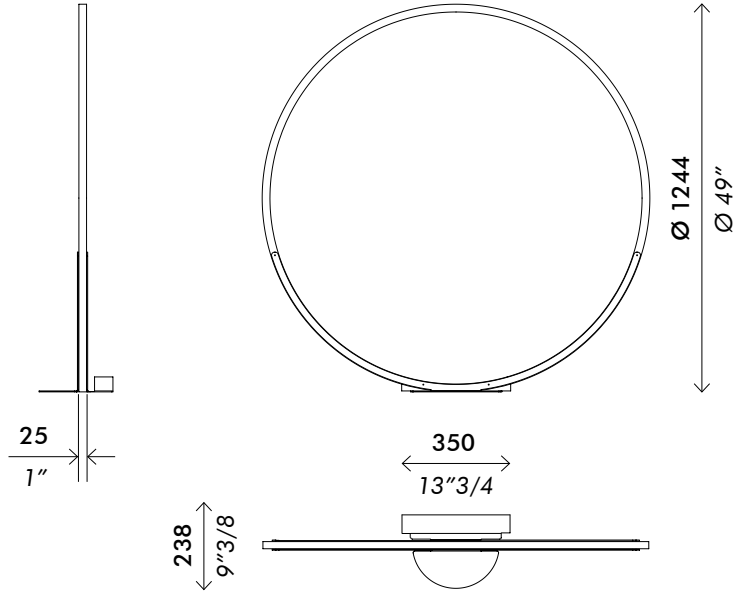

Luna F1250

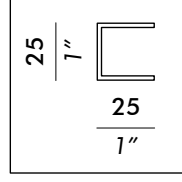
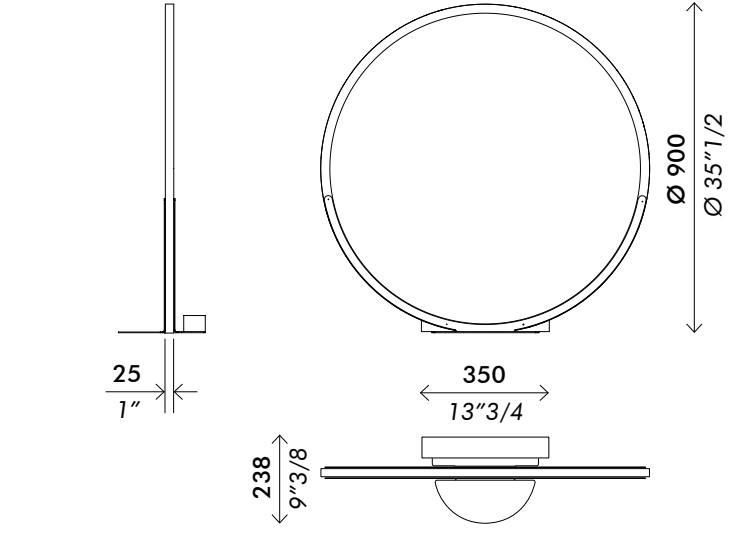

Luna F900

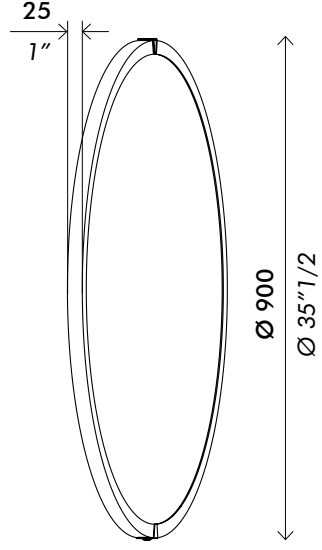

Luna A900

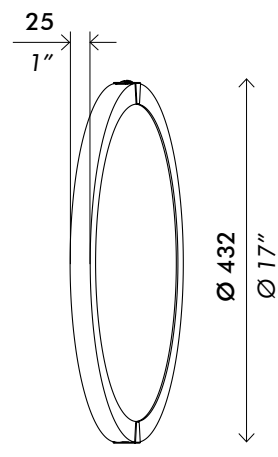
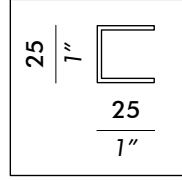

Luna A430

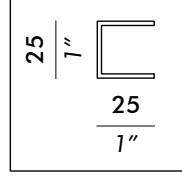

luna A1250

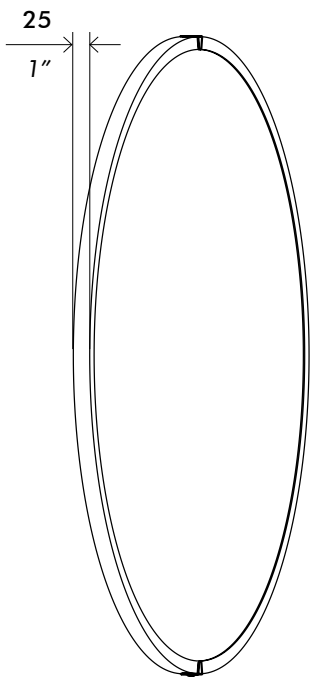
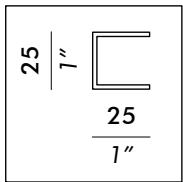

luna S1250  
+ S900 vertical

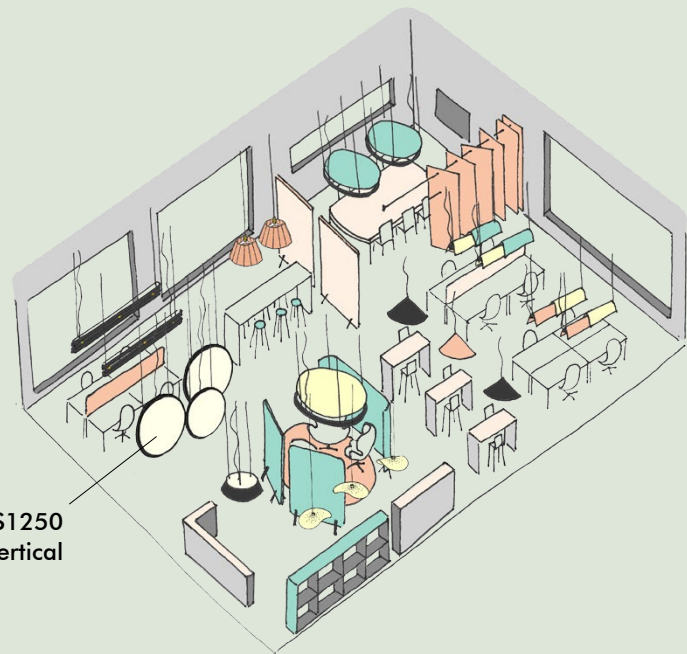

luna S1250 horizontal





COLLECTION

**monocolo**

**ANDCOSTA**

# monocolo

**Hanging and ceiling lamps  
Ø 90 mm with direct light.  
Aluminium structure embossed  
white or black or  
matt brass coated.  
Opal polycarbonate or transparent  
prismatic PMMA diffuser.  
LED COB.**

The essence of design  
that offers at the same  
time high lighting  
features, simplicity and  
clarity that lead to good  
design.  
Available both  
in hanging and ceiling  
version:  
**monocolo S90 and C90.**

**AndCosta R&D — 2018**











monocolo C90

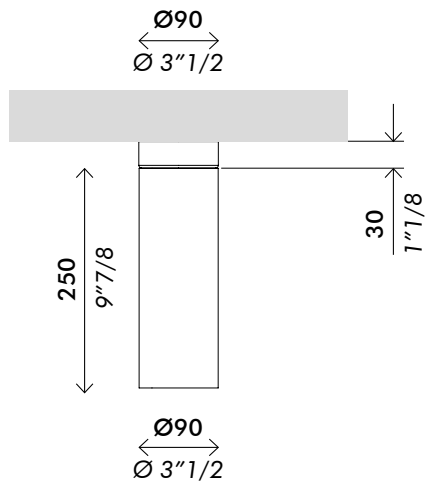

monocolo S90

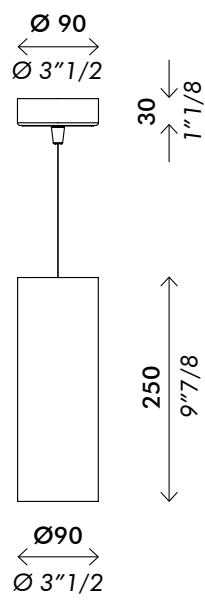

mm/inch



COLLECTION \_\_\_\_\_

**nova**

**ANDCOSTA**



**nova**

**Hanging and ceiling lamps with direct or direct and indirect light.  
Spun aluminium structure matt white, black or brass coated.  
Opal PMMA or transparent prismatic diffuser.  
LED module.**

**Nova** is a collection of ceiling and hanging lamps, adopting the latest LED modules that becomes even more interesting in the two hanging versions that combine **down light** with **upwards lighting**. A one-piece aluminium body gives a perfectly diffused lighting without glare, **suitable for office and contract spaces.**

**DESIGN AndCosta R&D — 2015**



**discover NOVA on our website** 









nova hanging lamps





nova S350



mm/inch

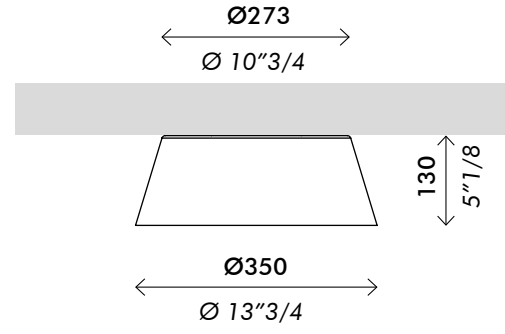

nova C350

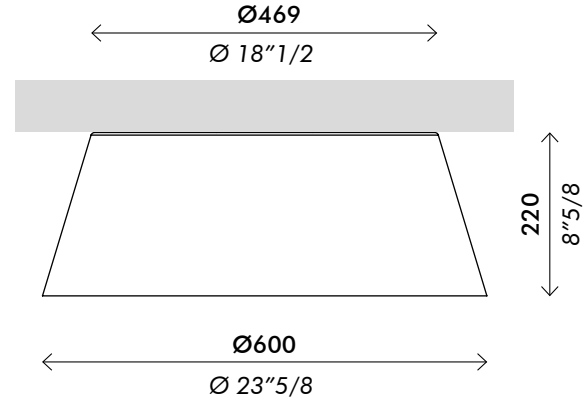

nova C600



nova C940

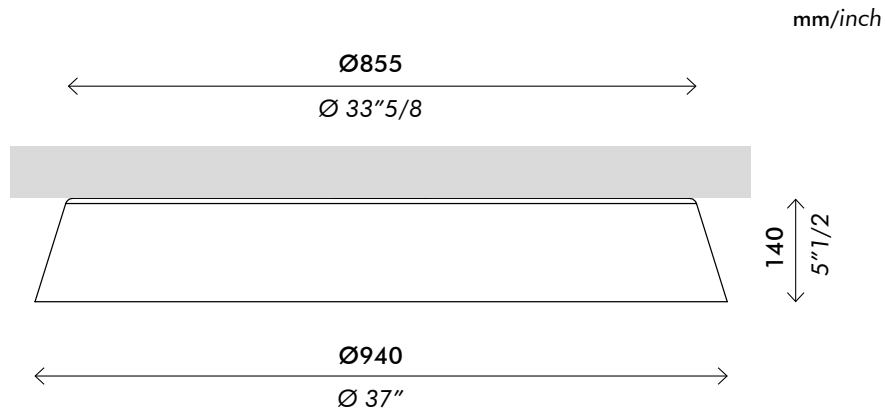

nova S350

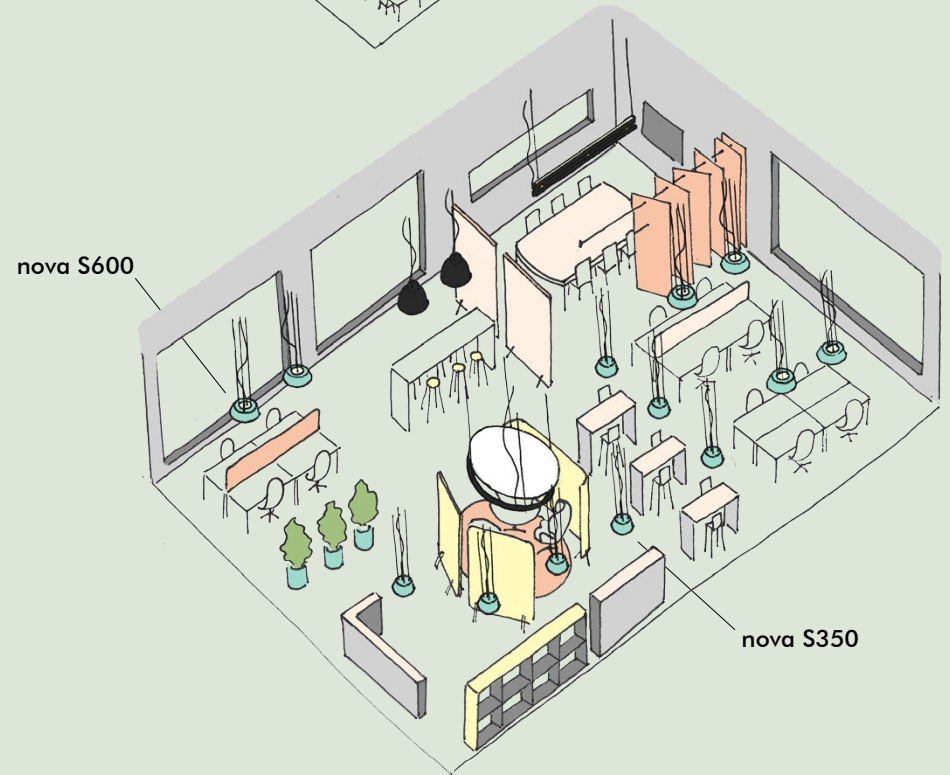
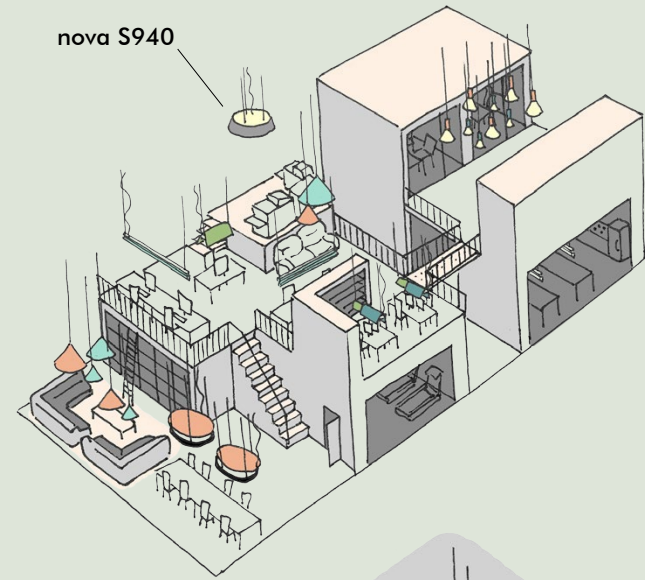
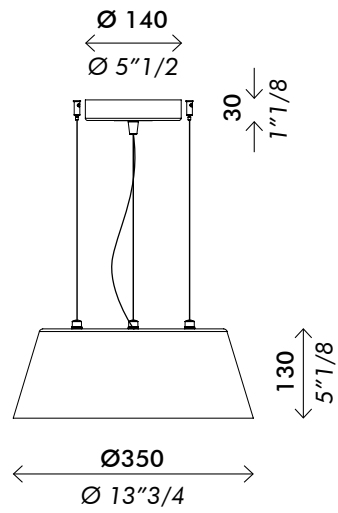

nova S600 up-down light

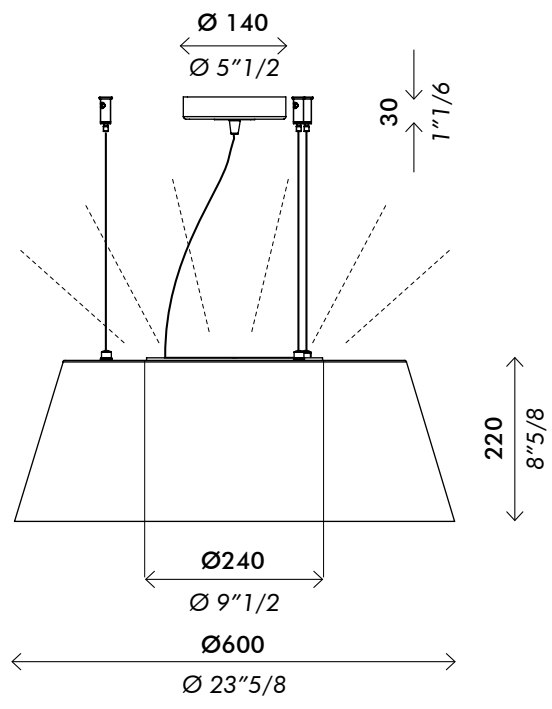

nova S600

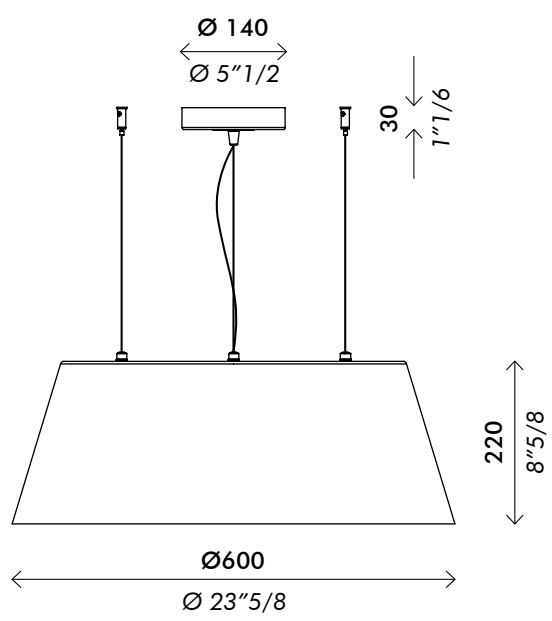

mm/inch



nova S940 up-down light

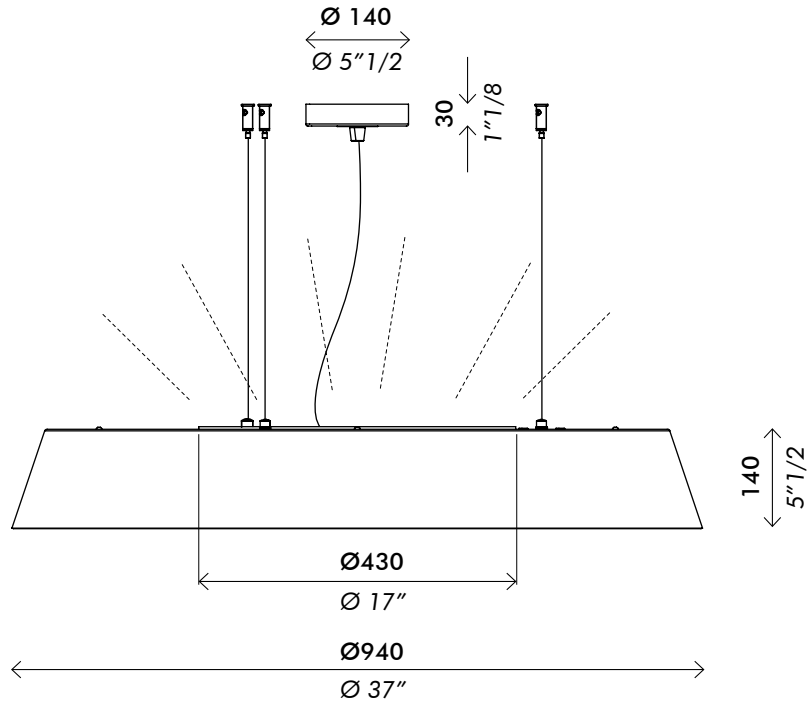

nova S940

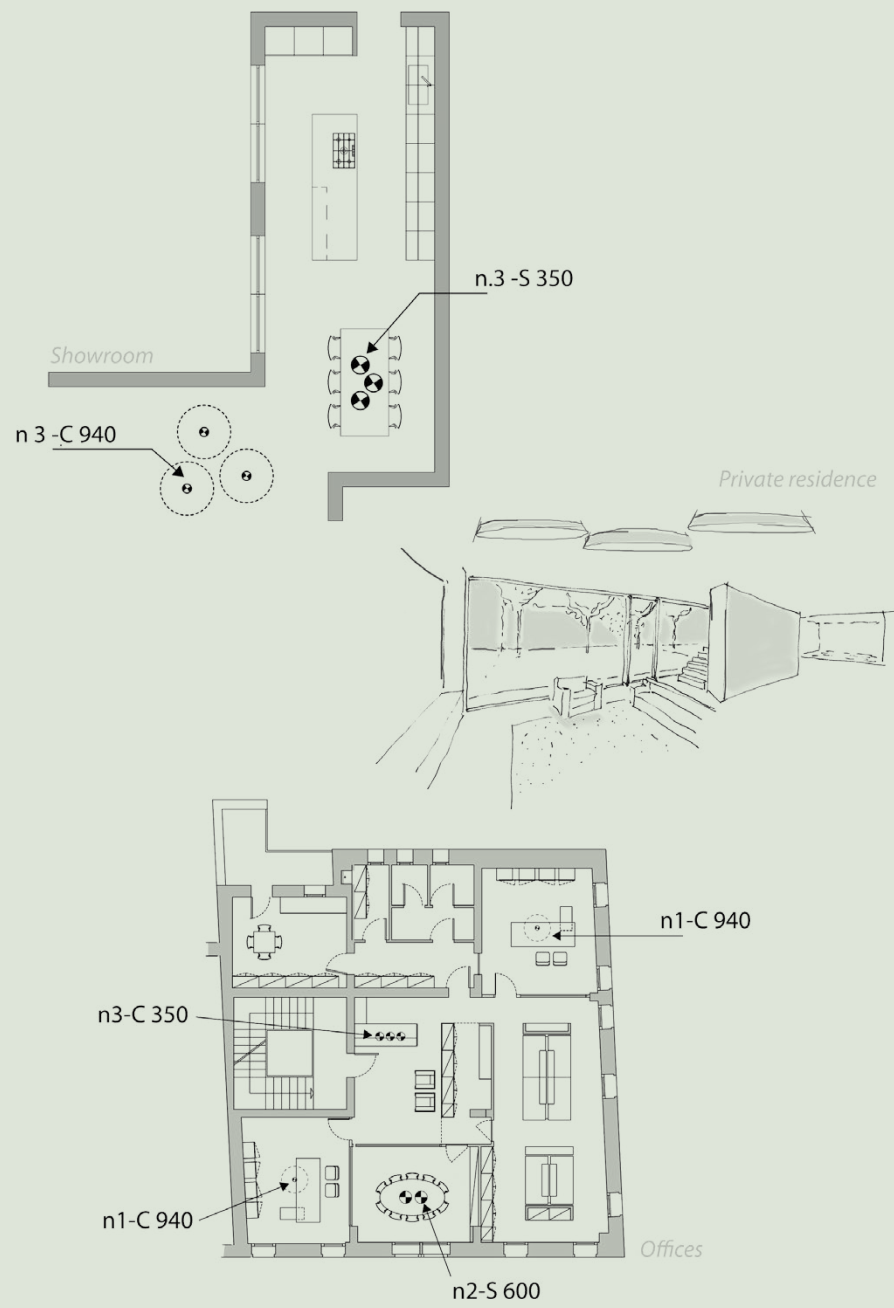
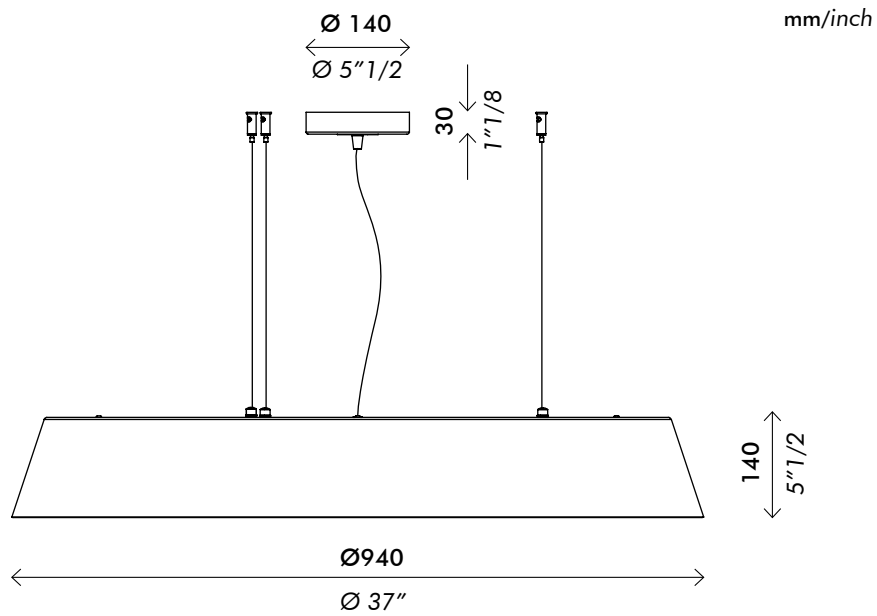

COLLECTION

**ritmo**

**ANDCOSTA**

# ritmo

A collection of hanging, ceiling and wall lamp with direct or indirect light.  
Aluminium structure matt white, black or brass coated.  
Opal polycarbonate or transparent prismatic diffuser.  
Strip LED.

“Musicians create rhythm in the spacing between notes, effectively making these “silent” gaps play off the notes.”  
As music, also the design of **ritmo** lamps shapes spaces using black and white in a balanced and unobtrusive proportion.

DESIGN Alessio Bassan — 2020







mm/inch

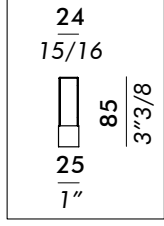
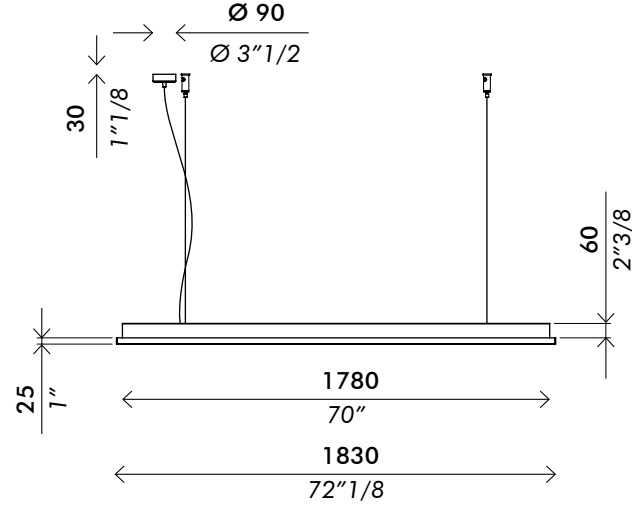

ritmo S1800

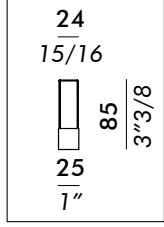
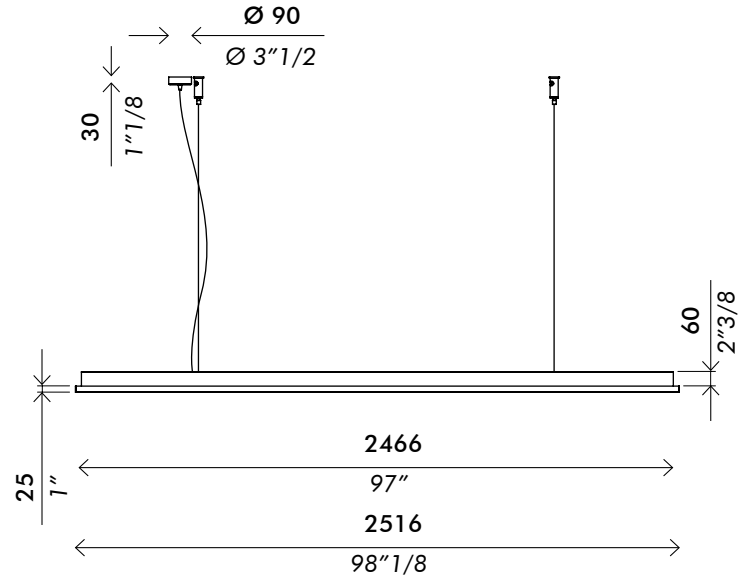

ritmo S2500



ritmo S1800







mm/inch

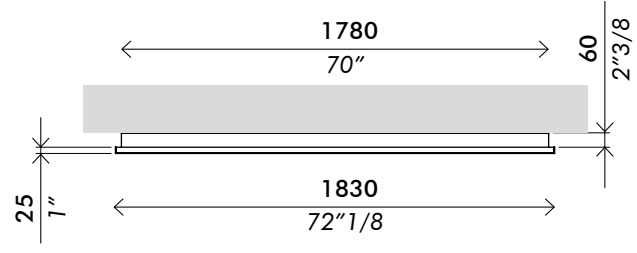

ritmo C1800

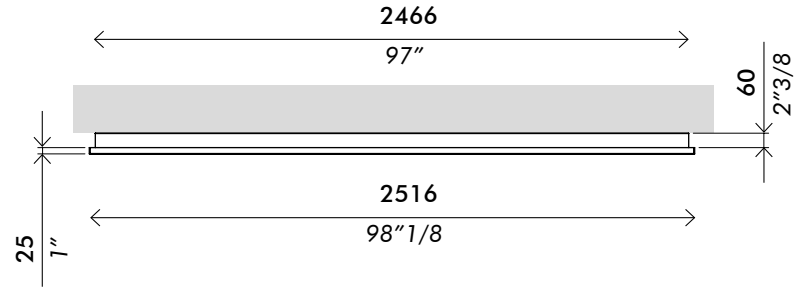
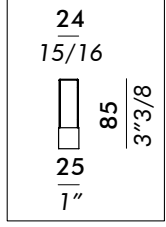

ritmo C2500

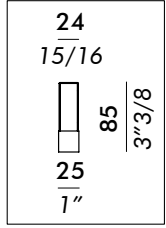





mm/inch

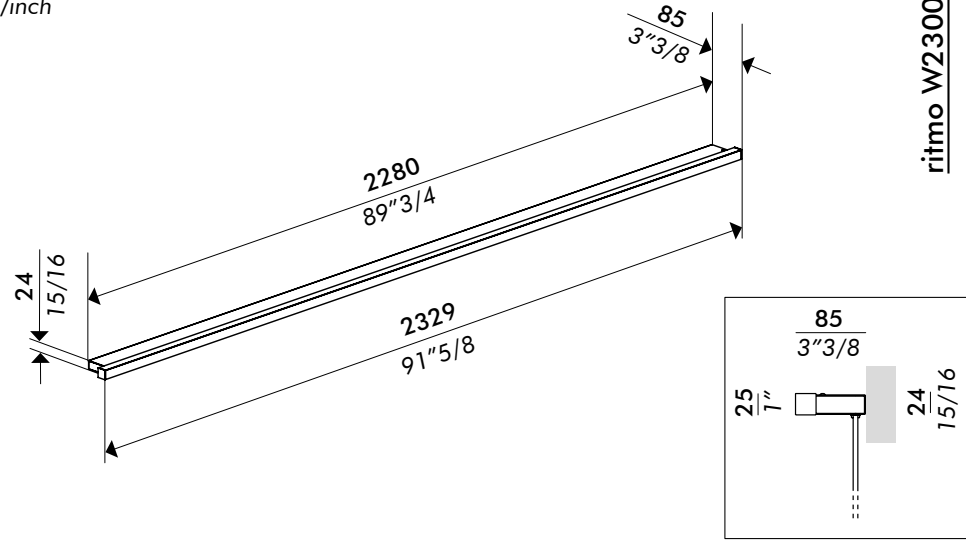





ritmo W1800

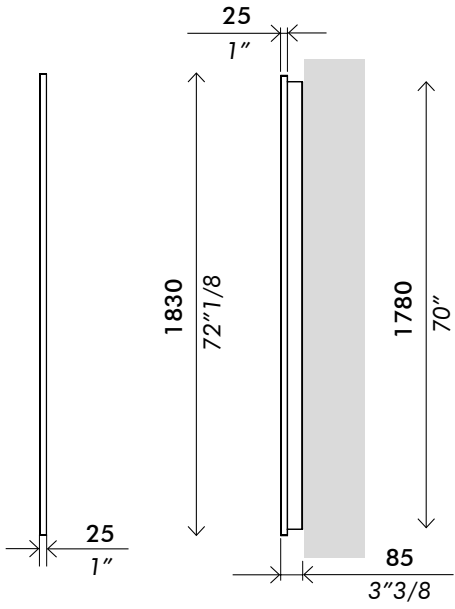
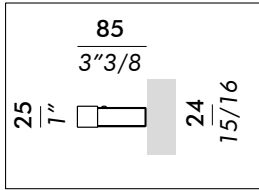

mm/inch

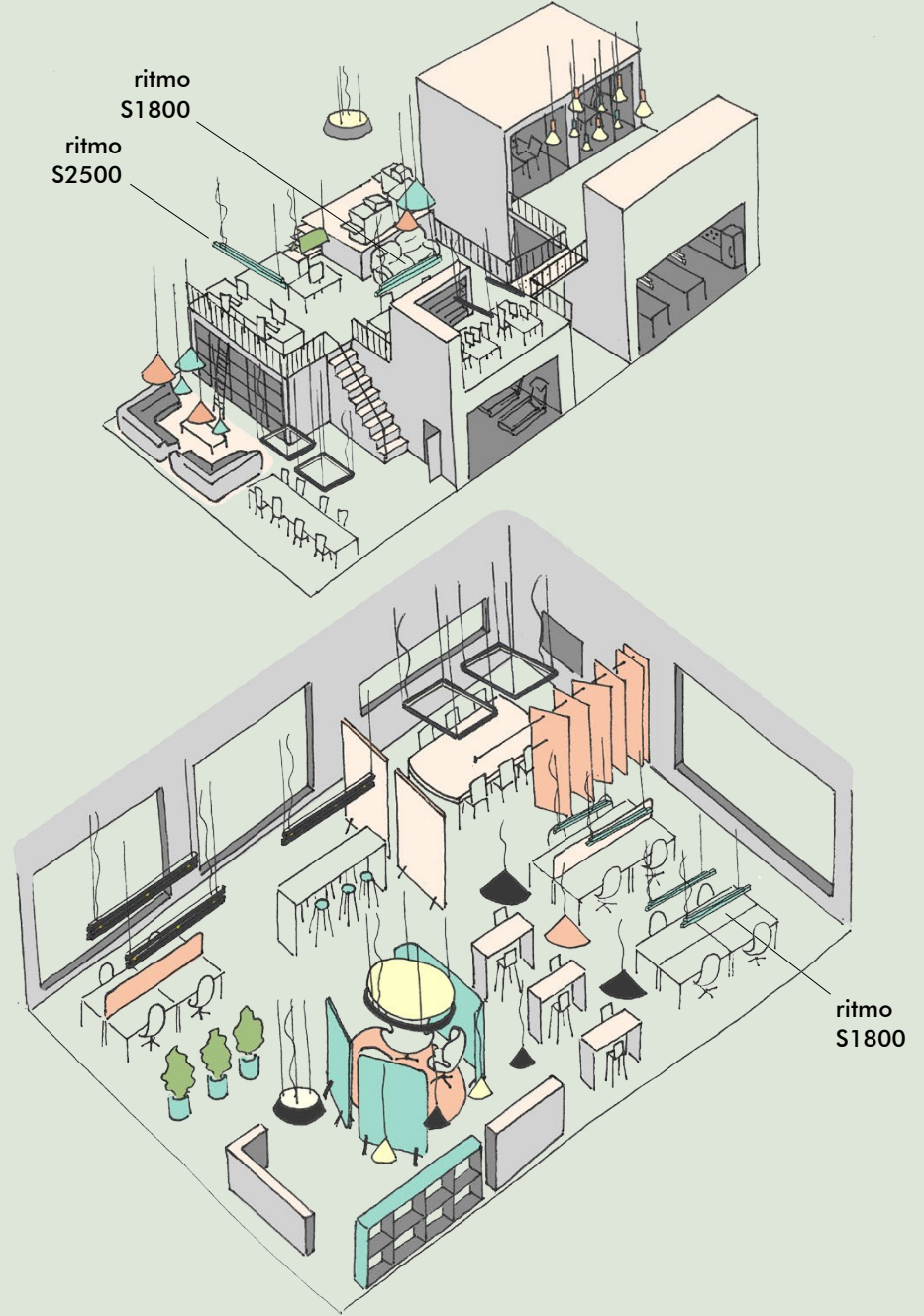

COLLECTION

**vitreo**

**ANDCOSTA**



# vitreo

**A collection of lamps with  
diffused light.  
Inner aluminium structure white,  
black or multicolor coated.  
Ribbed pyrex glass cylindrical diffuser.  
LED strip.**

The minimal design  
blends in a sublime light  
with a poetic expression.  
The shape of the glass  
cylinder, smooth on the  
outside, ribbed internally,  
returns an atmospheric  
rasterized light.  
**Vitreo offers endless  
possibilities  
of configuration.**

**DESIGN AndCosta Team \_\_\_\_\_ 2022**





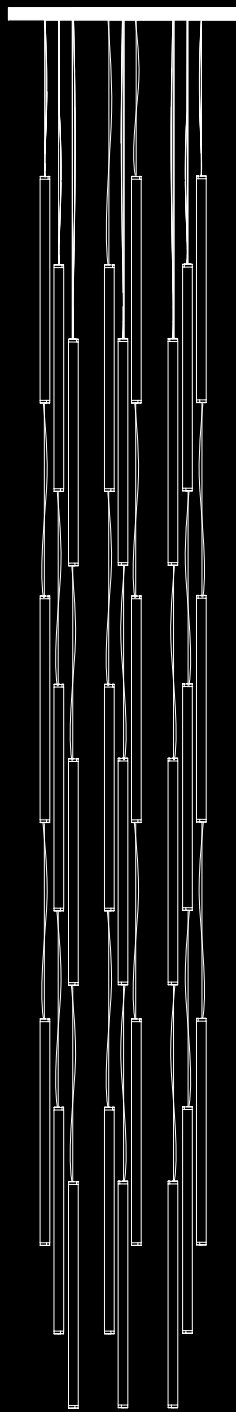

vitreo S1500 vertical  
custom composition

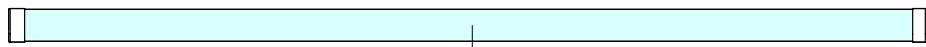

glass shell

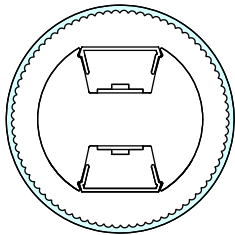

ribbed glass tube  
Ø60 mm

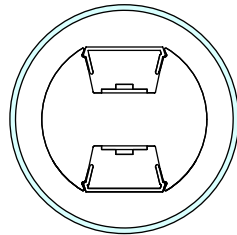

smooth glass tube  
Ø60 mm



aluminium inner structure

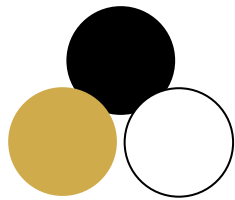

standard single colours

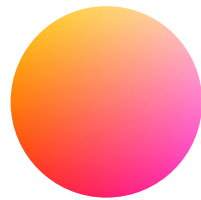

shades



vitreo S1500 horizontal



vitreo F1500

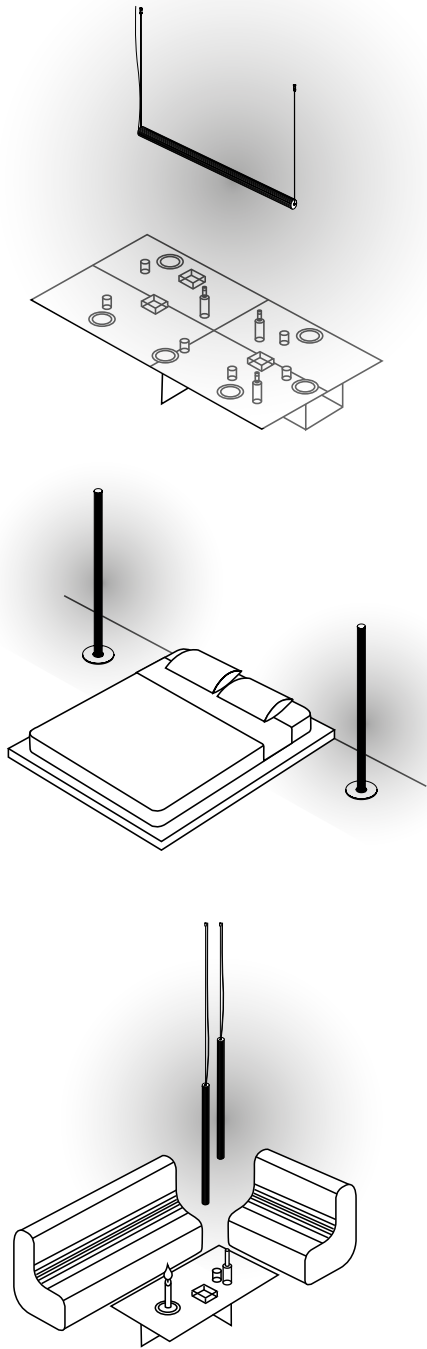

## Vitreo

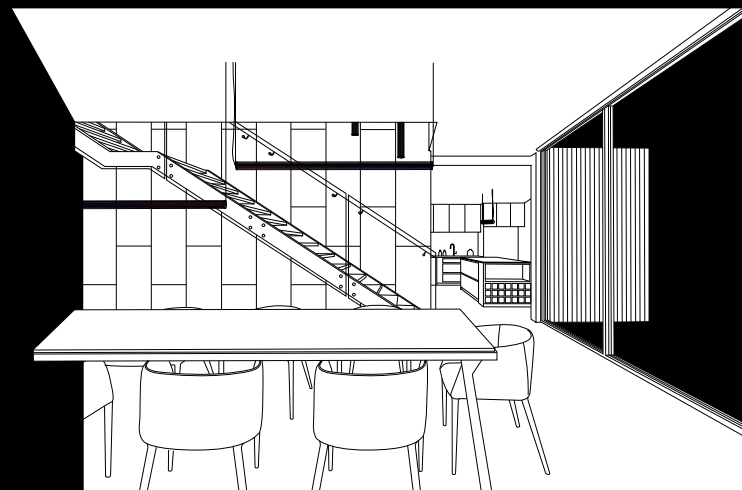

 ANDCOSTA

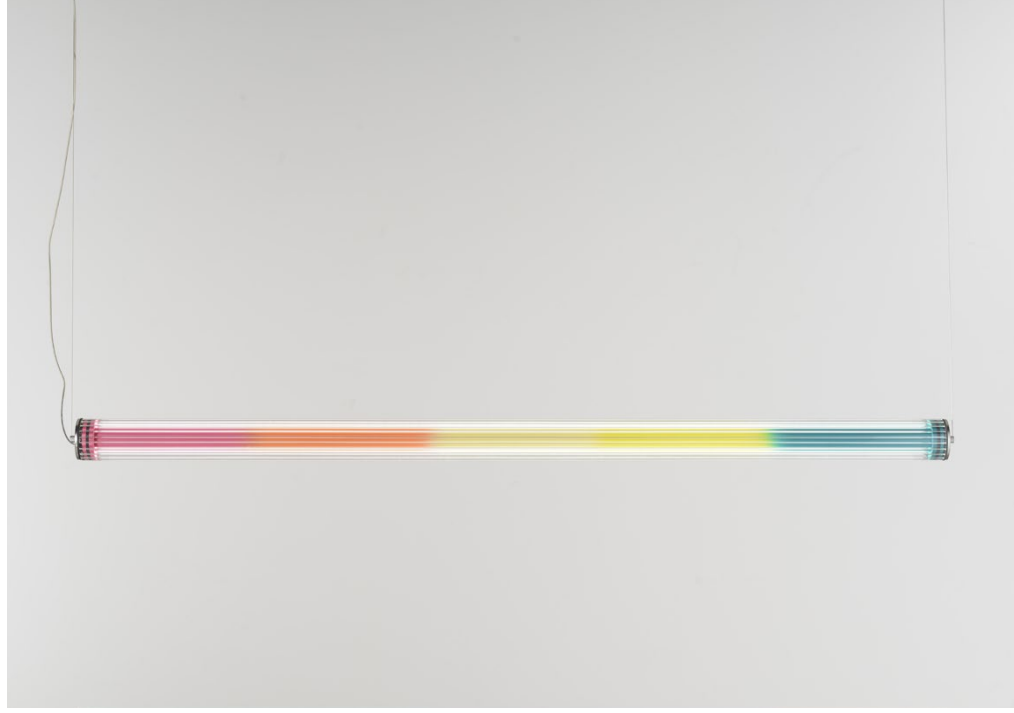

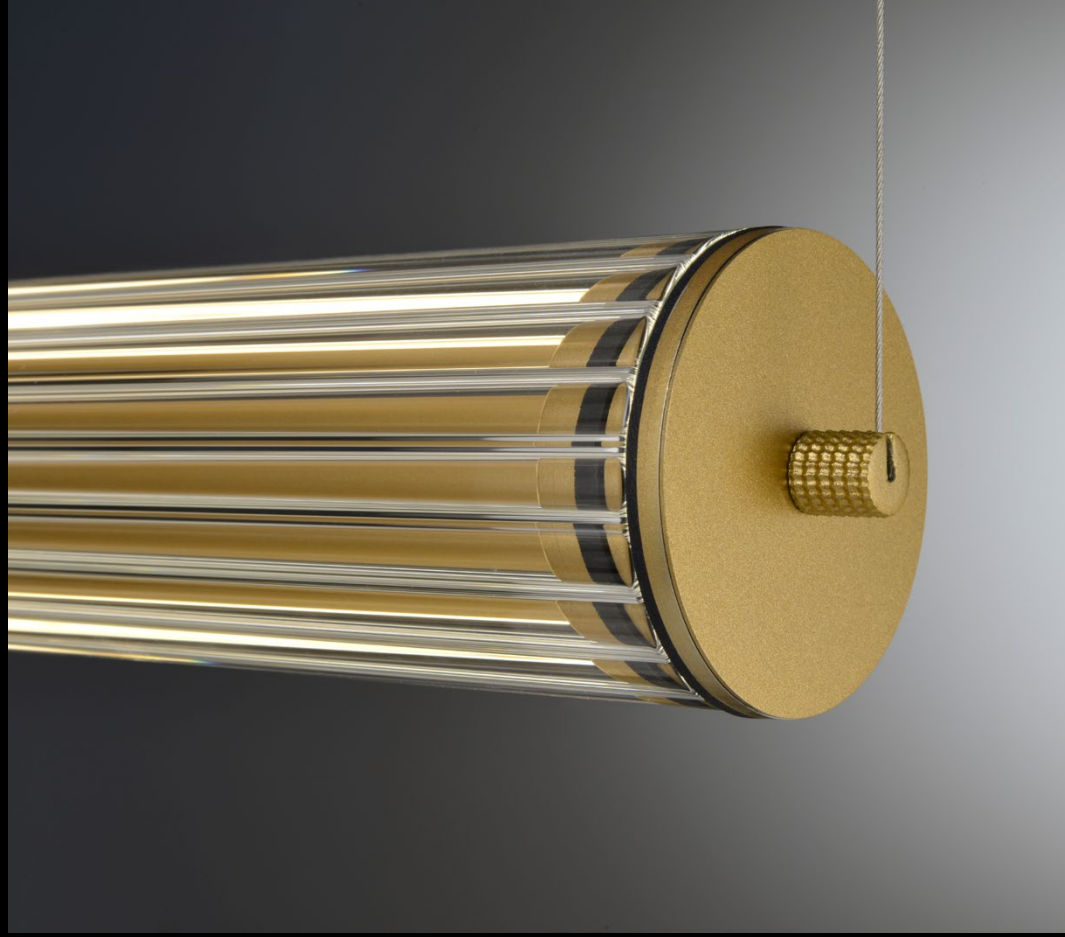
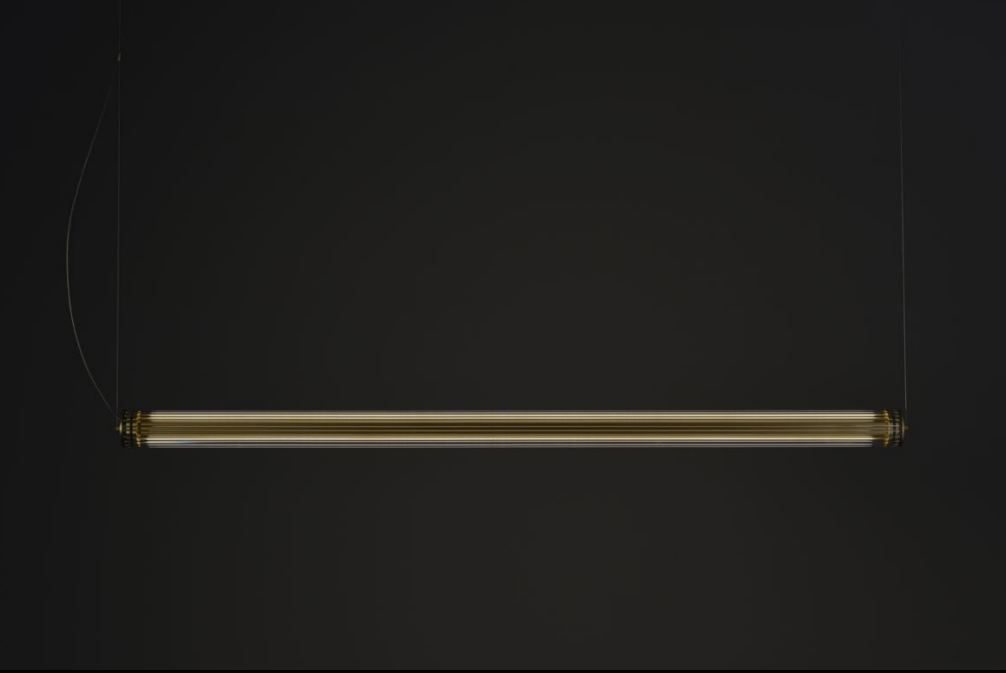



mm/inch

vitreo S1500 vertical

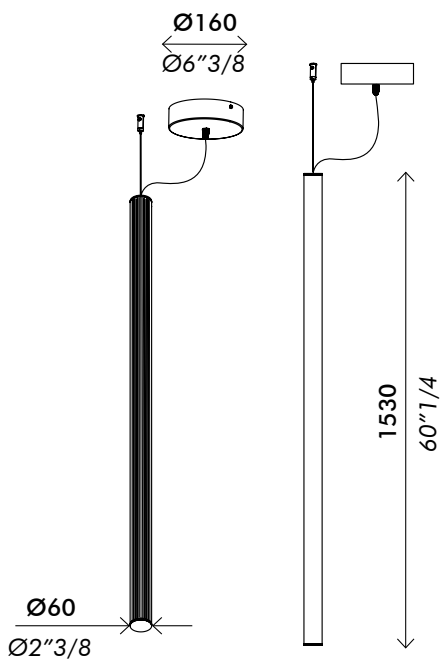
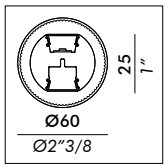

vitreo S1500 horizontal

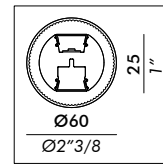
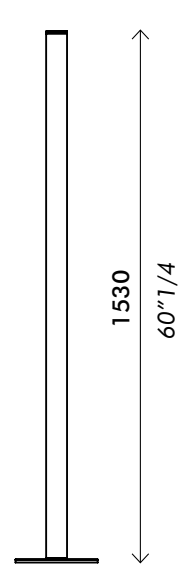
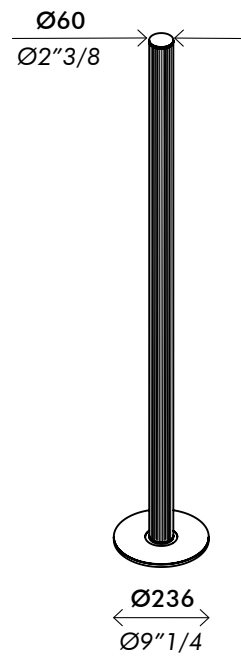
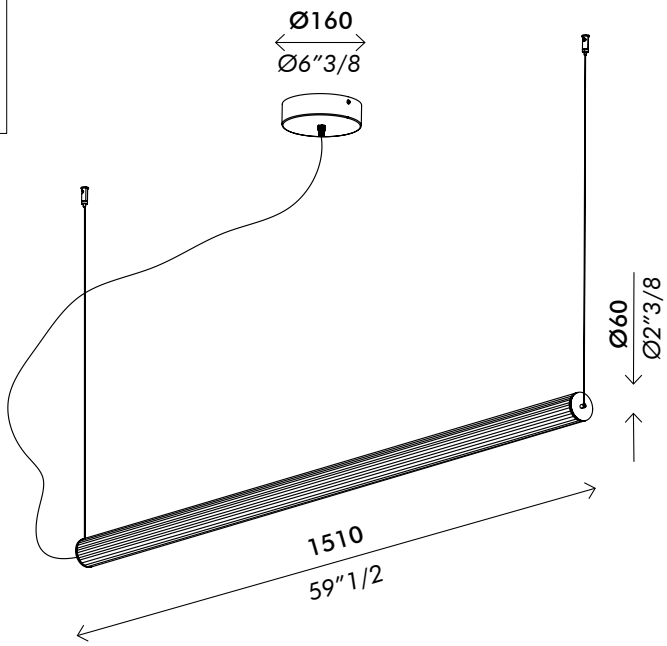
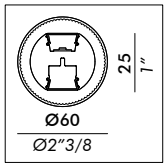

vitreo F1500

COLLECTION

**DECORATIVE**

**ANDCOSTA**

COLLECTION

**armando**

**ANDCOSTA**

# armando

**Hanging lamp with direct light.**  
**Aluminium structure ø700 mm**  
**matt white, black or brass coated.**  
**Metal ceiling canopy matt white,**  
**black or brass coated.**  
**LED bulb.**

As interesting as the  
shapes drawn by  
the light, there is the  
shadow that  
it produces

**DESIGN Carlo Zerbaro — 2020**

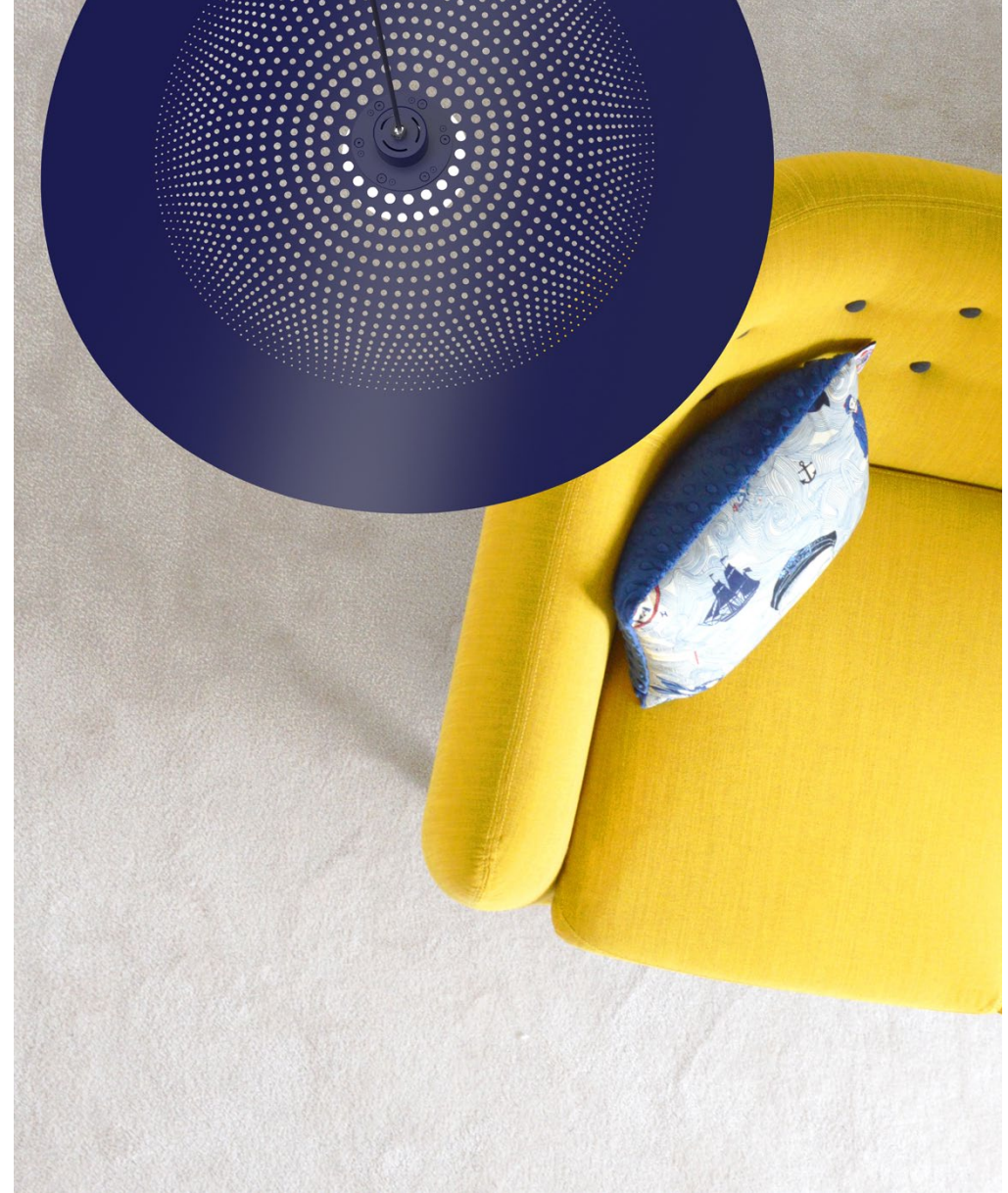



armando S700



armando S700

armando S700

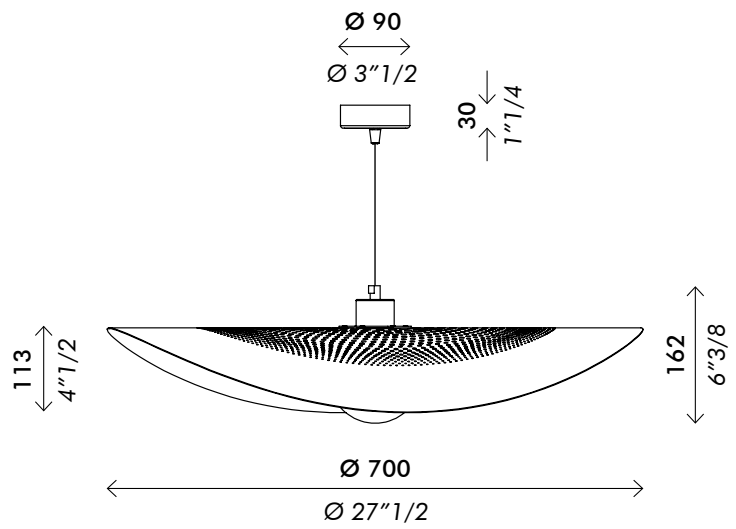

mm/inch



armando S700

COLLECTION \_\_\_\_\_

**cone**

**ANDCOSTA**



# cone

**Hanging lamps with direct or direct and indirect light.**  
**Spun aluminium structure matt white, black or brass coated.**  
**Opal polycarbonate or transparent prismatic PMMA diffuser.**  
**Metal ceiling canopy matt white, black or brass coated.**  
**LED module.**

A collection of hanging lamps with a **basic shape** expressing the **downtight iconography.** Available in **three sizes**, the smaller one is available **also in serial or cluster compositions**, while the largest is also for **direct and indirect lighting.**

**DESIGN AndCosta R&D — 2015**



**discover CONE on our website** 



cone S120.3





cone S340





cone S570 up-down light



mm/inch

0\_1-10 / DALI

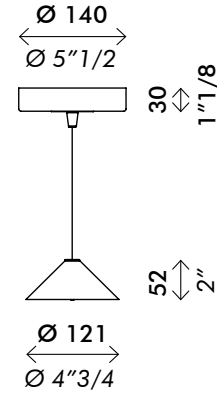

on-off

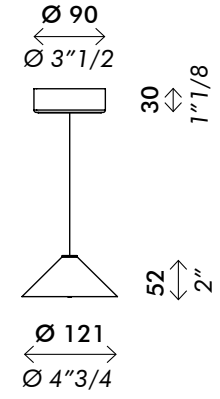

cone S120

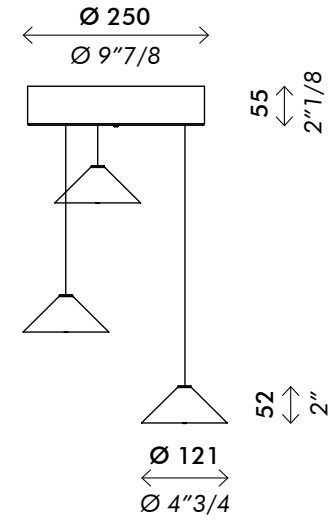

cone S120.3

**cone S120.5**

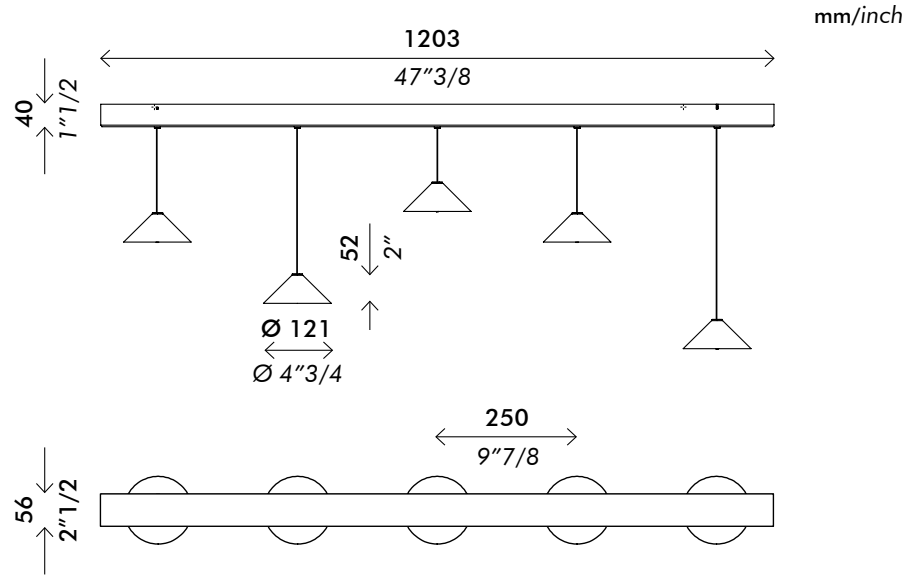

**cone S340**

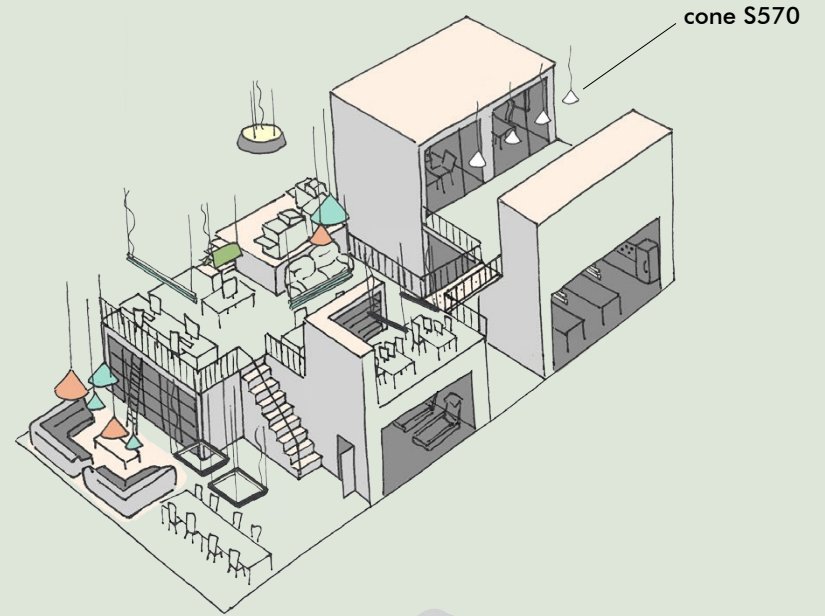
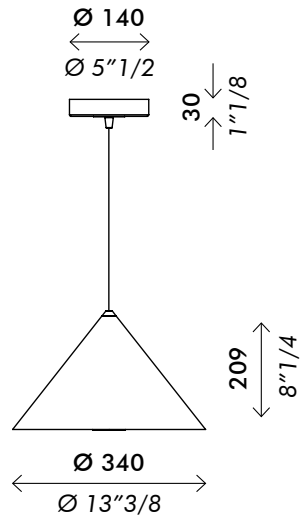



cone S570 up-down light

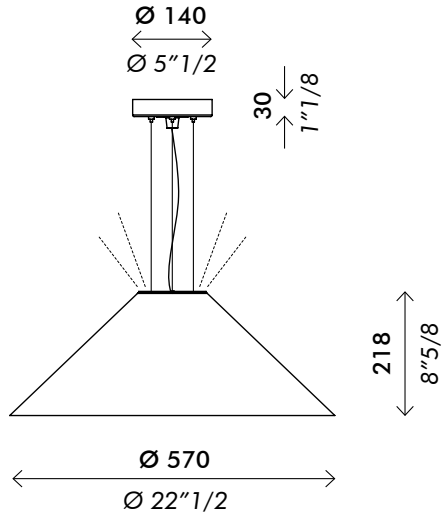

cone S570

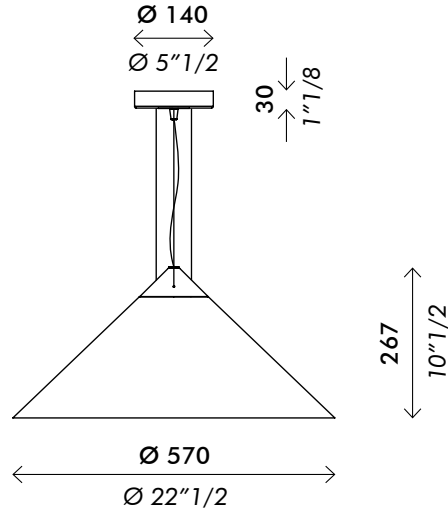

mm/inch

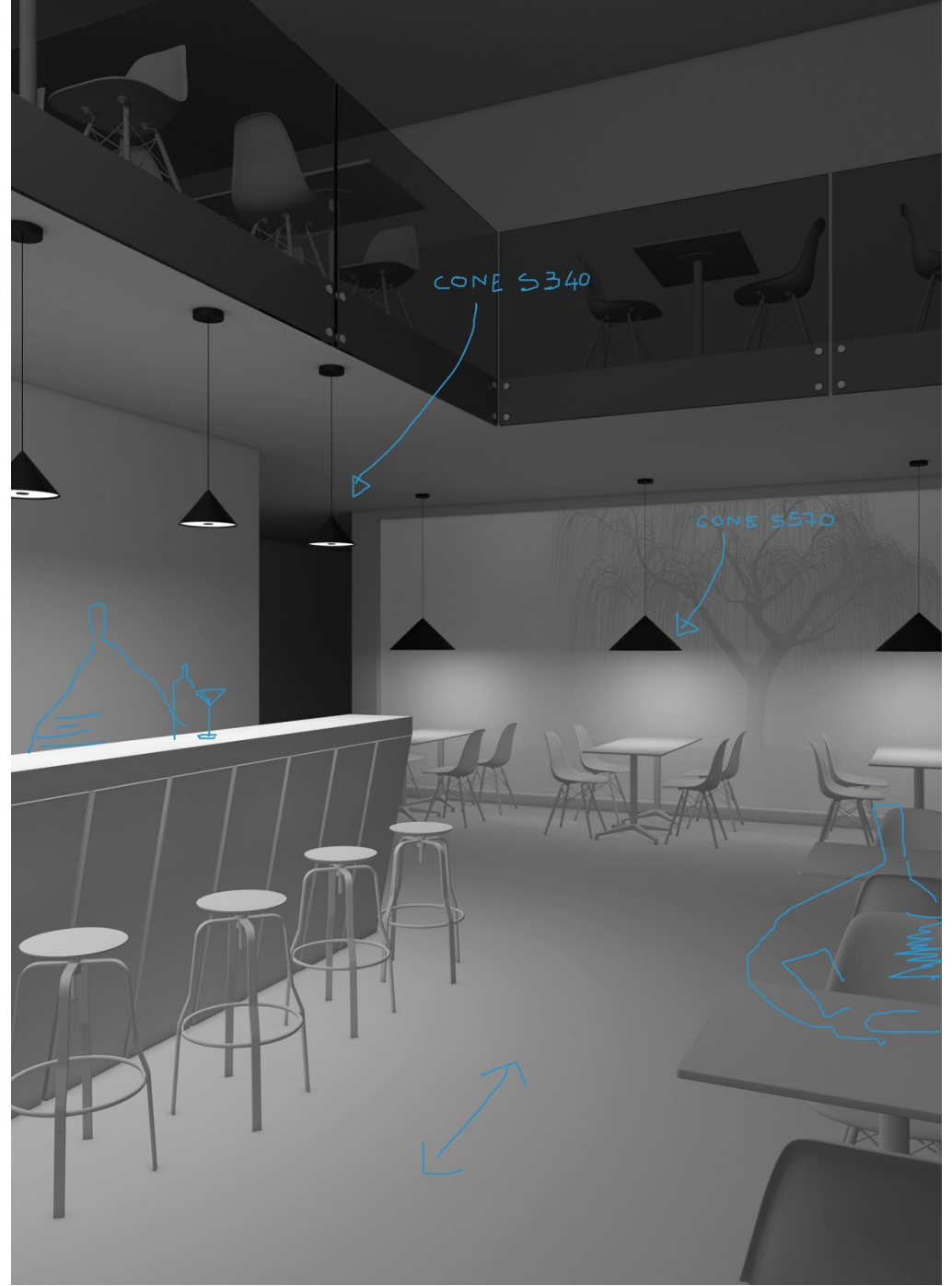

COLLECTION

**flat**

**ANDCOSTA**

# flat

**Hanging lamp with direct light.**  
**Spun aluminium structure matt**  
**white, black or brass coated.**  
**Opal PMMA or transparent**  
**prismatic diffuser.**  
**Metal ceiling canopy matt white,**  
**black or brass coated.**  
**LED module.**

Enhanced by the  
assonance between  
the words  
float and **flat**  
this product born from  
the want to joint the  
highest **LED efficiency**  
to the **sober shape**  
of the body.

**DESIGN AndCosta R&D — 2020**



[discover FLAT on our website](#) 



**flat S500**

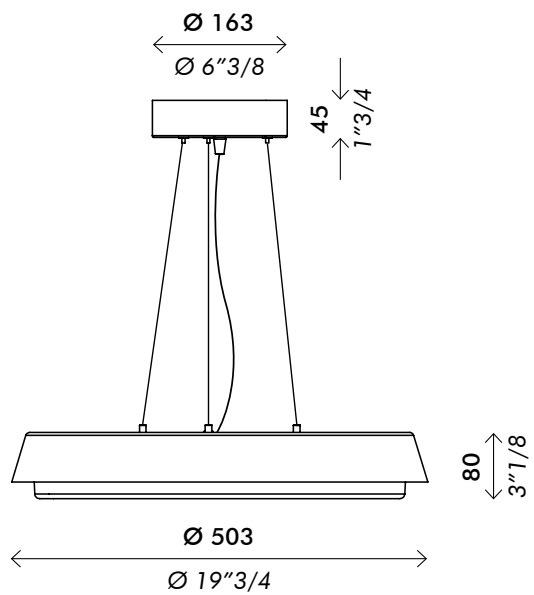

mm/inch



COLLECTION \_\_\_\_\_

**grue**

**ANDCOSTA**

# grue

**Floor lamp with direct light.  
Adjustable and fully foldable  
aluminium structure matt white,  
black or brass coated.  
Opal polycarbonate or transparent  
prismatic diffuser.  
Steel base matt white, black  
or brass coated.  
LED module.**

A condensed masterpiece  
of engineering,  
**grue** is an adjustable  
configuration floor lamp  
with a LED module  
perfectly integrated  
in its directional  
outer arm.

**DESIGN Nicolas Stadler — 2014**



discover GRUE on our website 



grue F2000







mm/inch

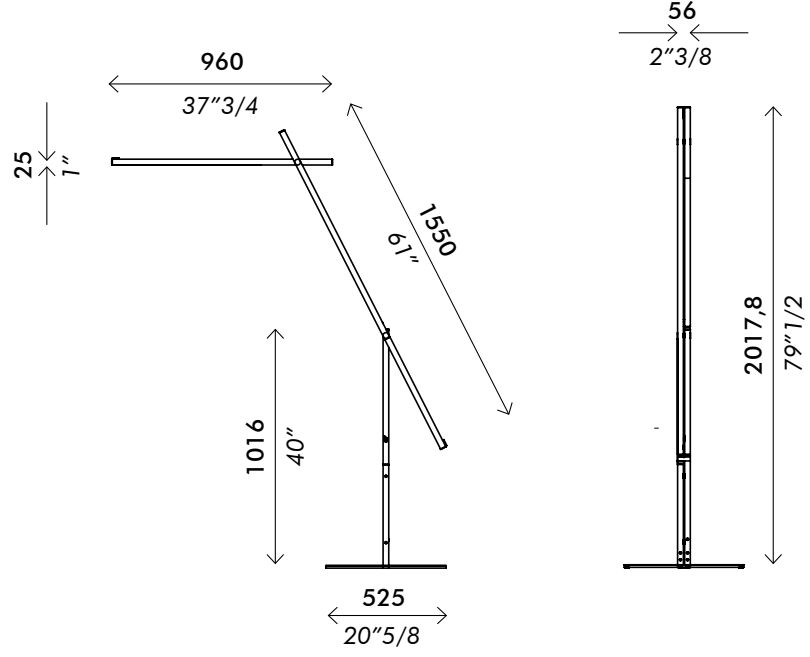

grue F2000

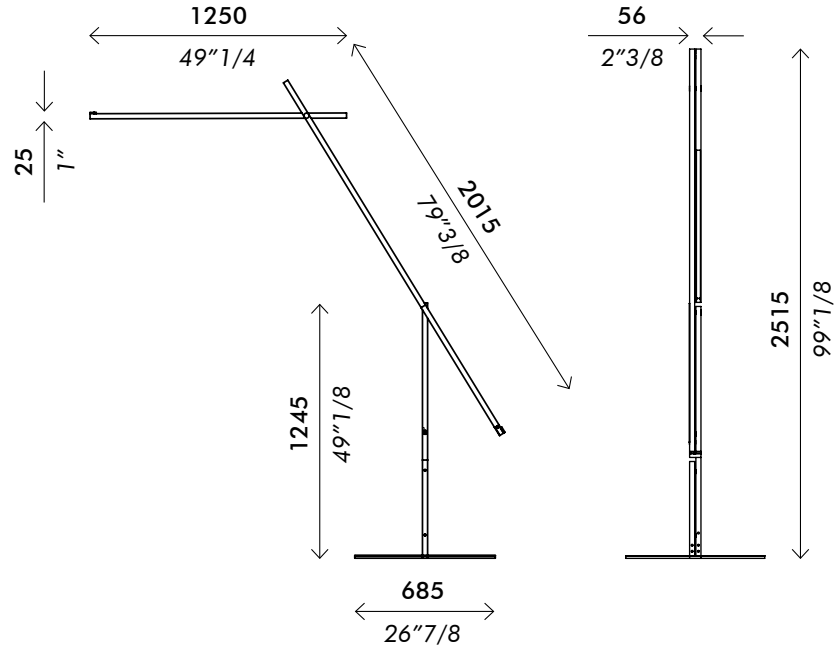

grue F2500

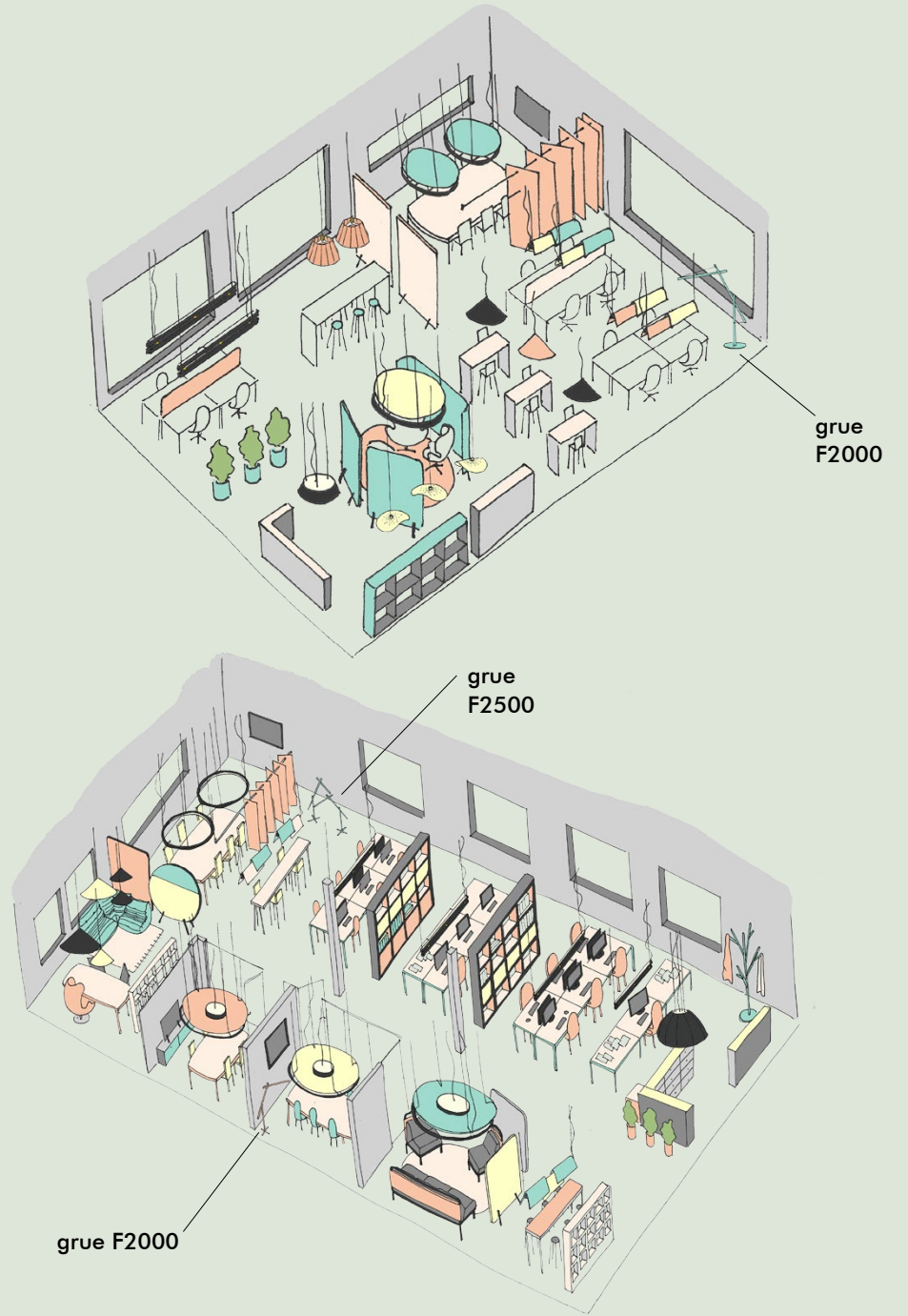
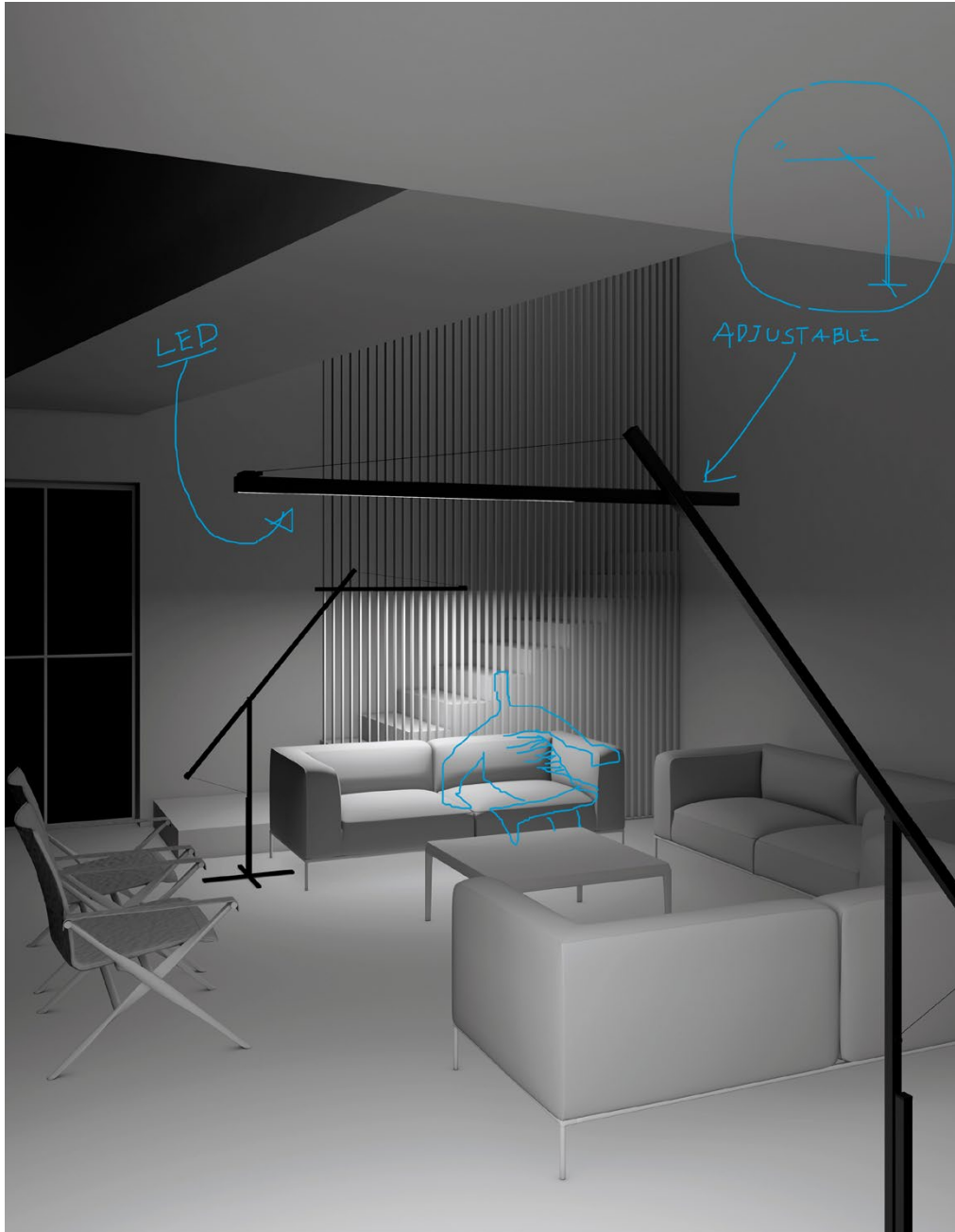

COLLECTION

**klokke**

**ANDCOSTA**

# klokke

**Hanging lamps with direct light.**  
**Spun aluminium structure embossed white or black or matt brass coated outside and matt white coated inside.**  
**Opal polycarbonate or transparent prismatic PMMA diffusers.**  
**Metal ceiling canopy embossed white or black or matt brass coated.**  
**LED module.**

This product is available in two sizes:  
**Klokke S350** Ø350 mm  
**and Klokke S500**  
Ø500 mm.

**DESIGN AndCosta R&D — 2018**



discover KLOKKE on our website 



klokke S500





klokke S350



klokke S500

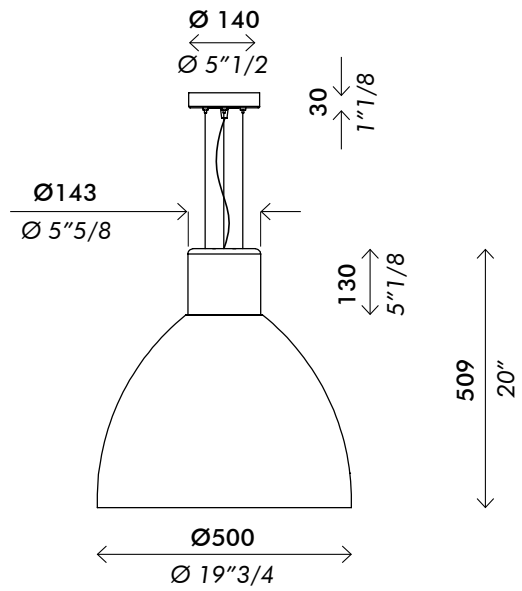

mm/inch

klokke S350

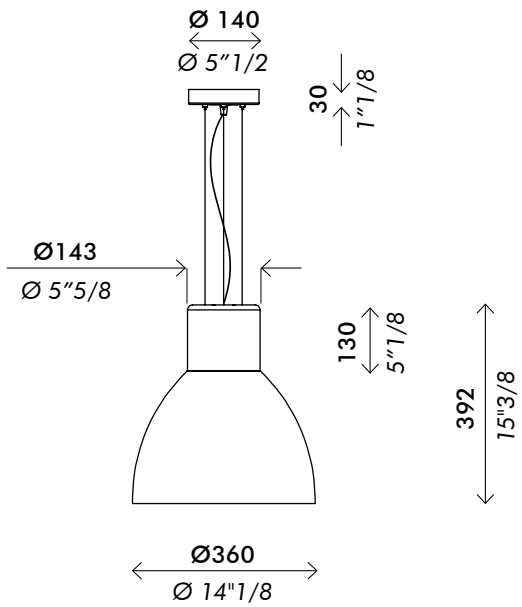

COLLECTION \_\_\_\_\_

**mecano**

**ANDCOSTA**

# mecano

**Floor and table lamps with diffused light.**  
**Adjustable steel structure with joints and base gunmetal coated.**  
**Fabric lampshade grey or black outside and white inside. Others colours or finish on request.**  
**Opal polycarbonate diffuser.**  
**LED bulb.**

Mecano's character plays with the lays of gravity and mechanics.  
Available in three versions, **mecano F2200**, **mecano F1900** and **mecano T600**, it has a fully articulated structure and fabric diffuser.

**Alessio Bassan** ——— **2014**



discover MECANO on our website 





mecano F2200





mm/inch

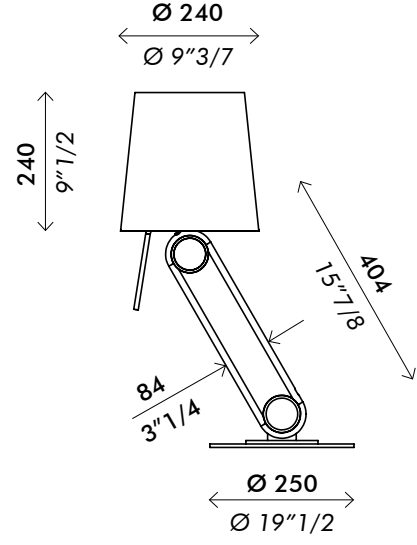

mecano T600

**mecano F1800**

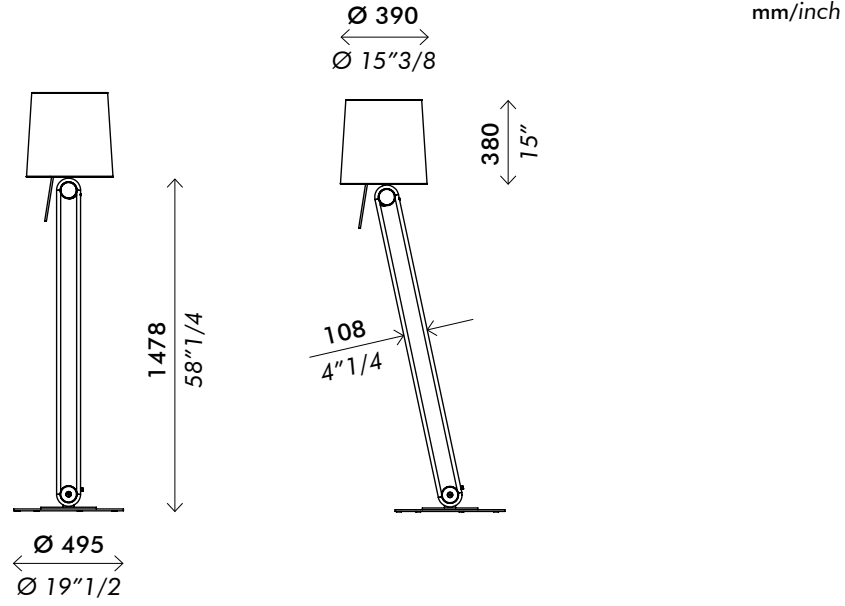

**mecano F2200**

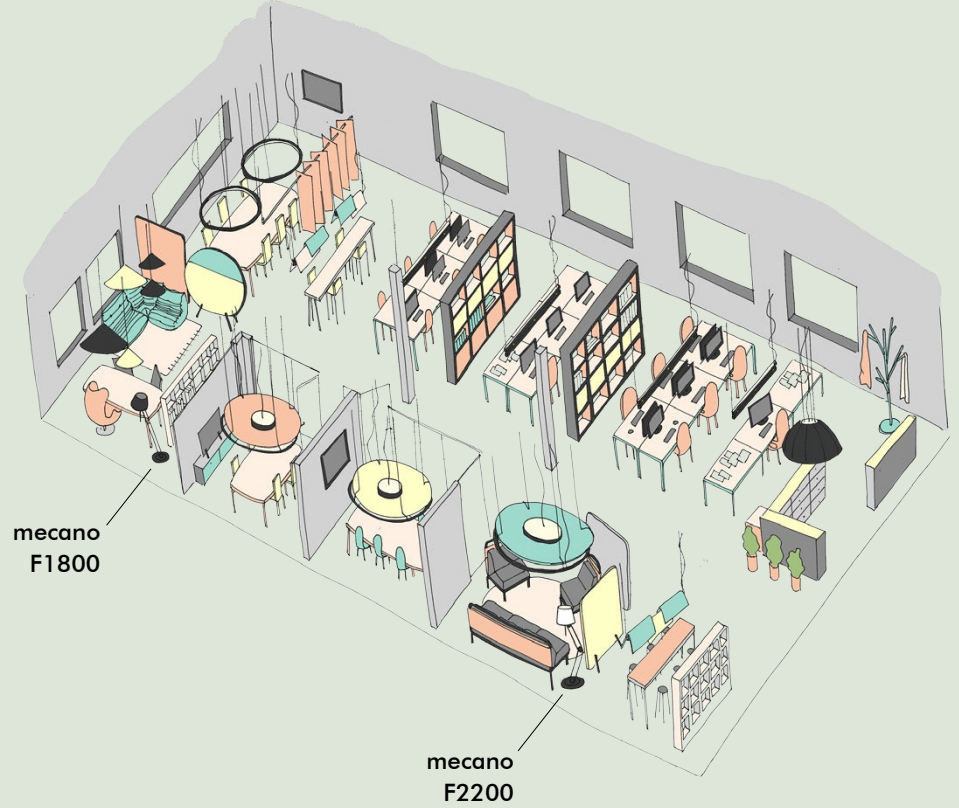
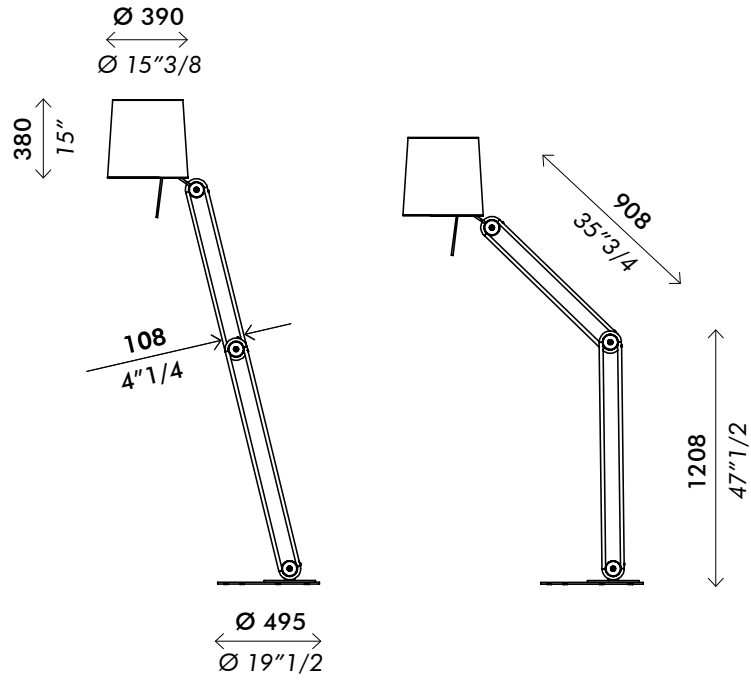



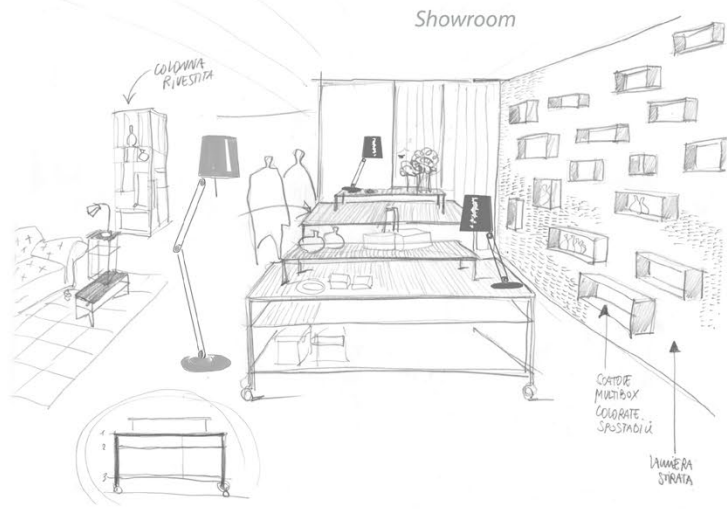

Private Residence

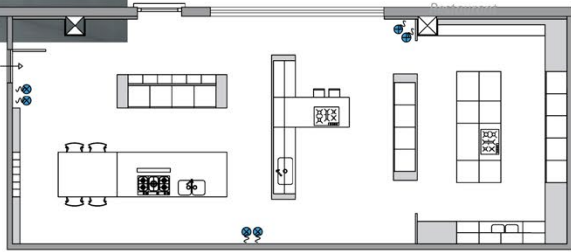

Showroom

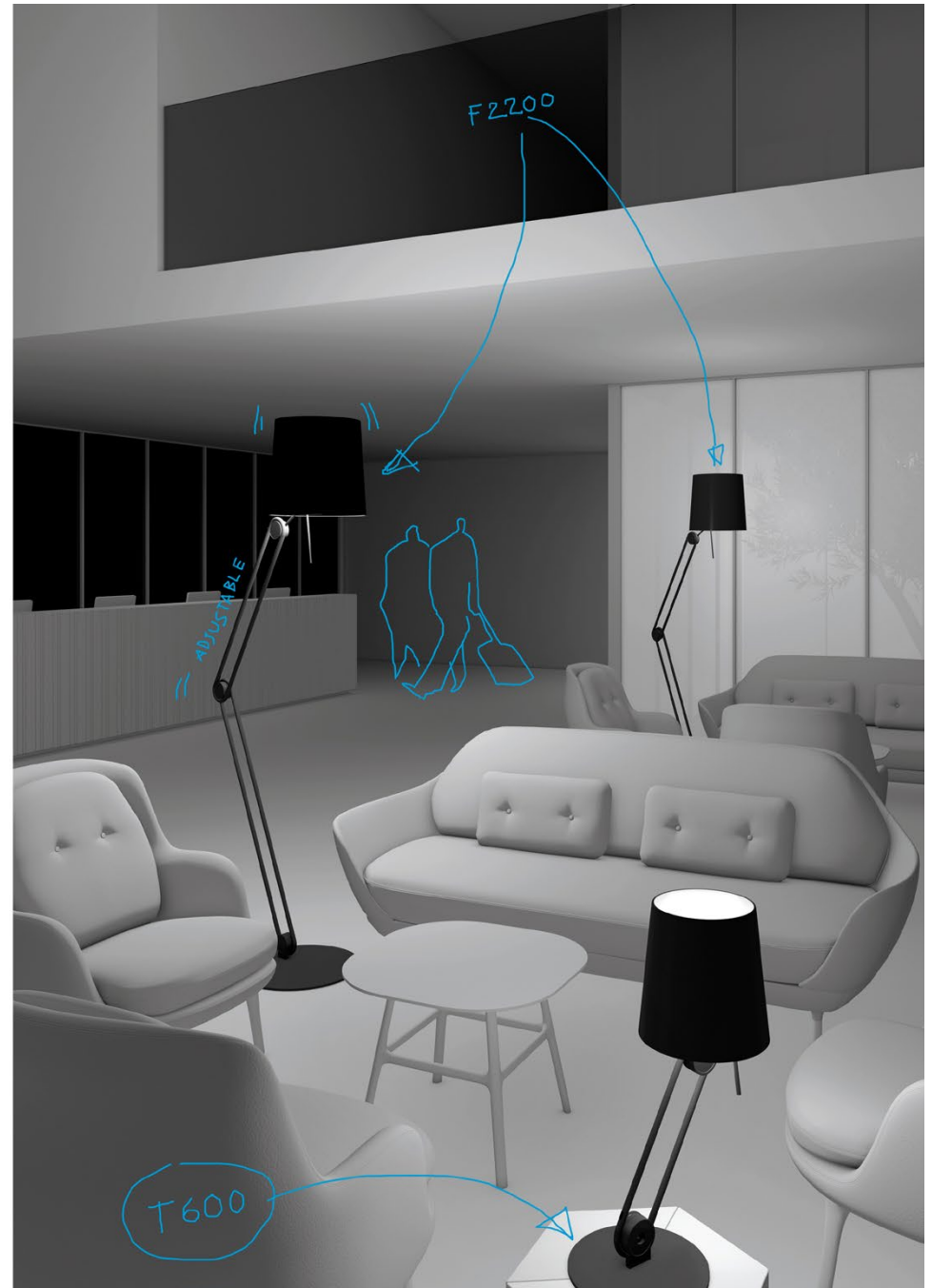

COLLECTION

**peak**

**ANDCOSTA**

# peak

**Hanging lamps with direct light.**  
**Cotton lampshade in white or black**  
**finish outside and white finish inside.**  
**Others colours or finish on request.**  
**Metal ceiling canopy matt white coated.**  
**LED bulb.**

With its volume,  
in addition to illuminating  
the room, it shapes  
the environment  
creating geometric and  
chromatic games.  
Available in two sizes,  
**peak S1000**  
and **peak S500,**  
lampshade's colour  
is customizable  
on request.

**DESIGN AndCosta R&D — 2020**



**discover PEAK on our website** 







peak S500



peak S1000

peak S500

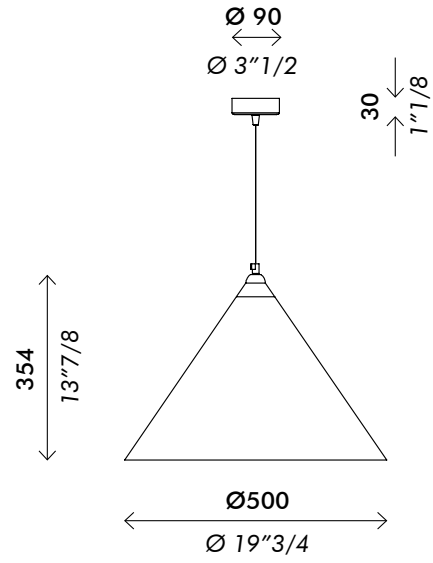

mm/inch

peak S1000

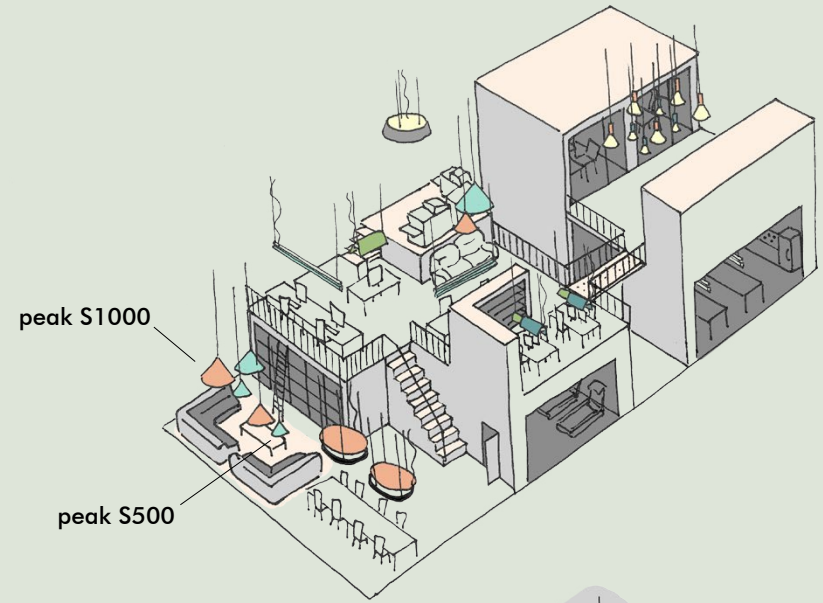
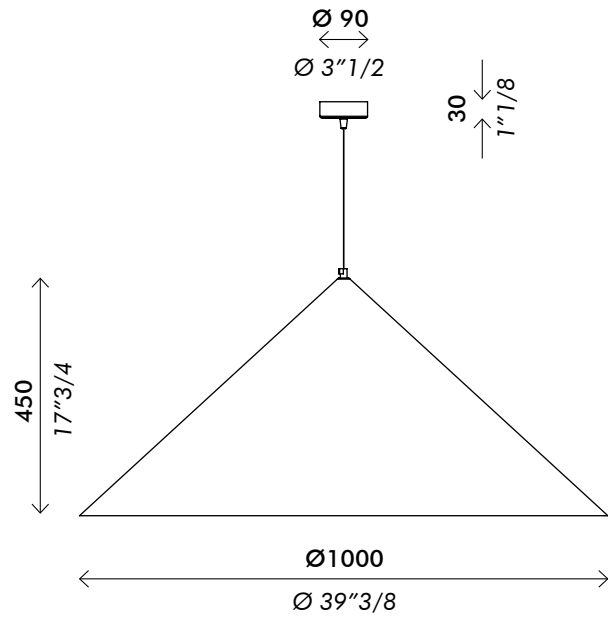



COLLECTION

**pin**

**ANDCOSTA**

# pin

**A collection of lamps  
with diffused light.  
Gloss white blown glass diffuser.  
Metal structure matt white,  
black or brass coated.  
LED COB.**

A sign of tradition and  
modernity and a tribute  
to a dear friend.  
Pin is a collection of  
lamps with a clear and  
essential design,  
characterized by  
precious opal blown  
glass diffuser.  
Available in various  
types and with different  
finish.

**DESIGN Cédric Ragot — 2014**



discover PIN on our website 





mm/inch

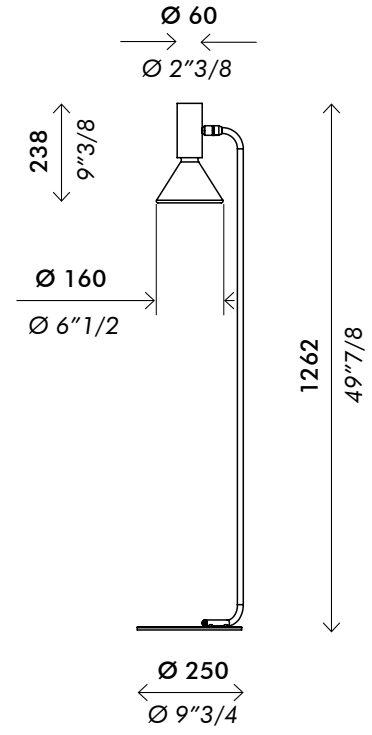

pin F1200



mm/inch

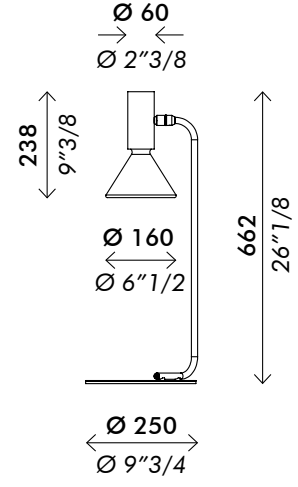

pin T670



pin T370



mm/inch

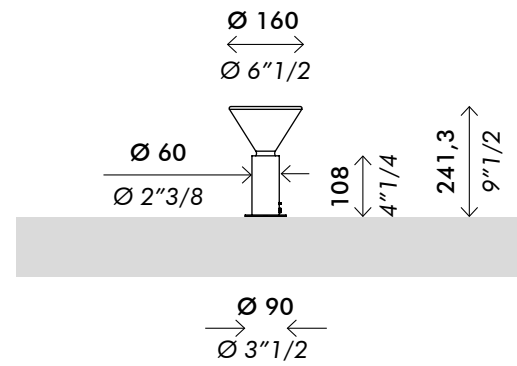

pin T160

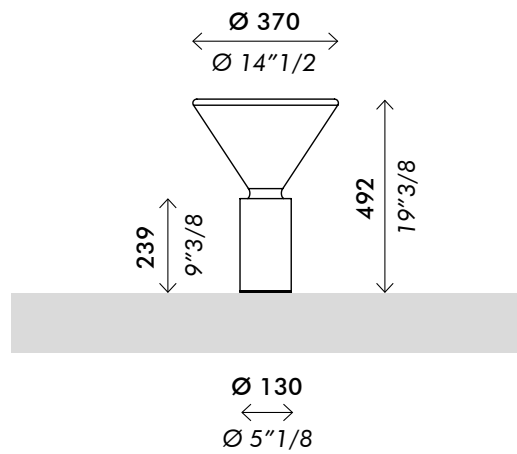

pin T370







pin S370

pin S160



mm/inch

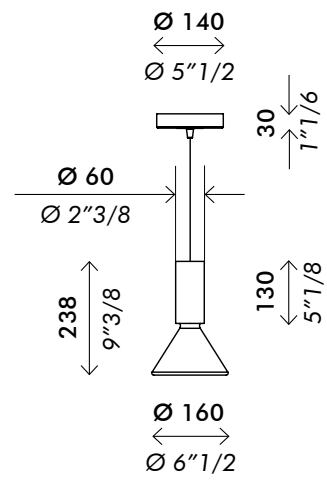

pin S160

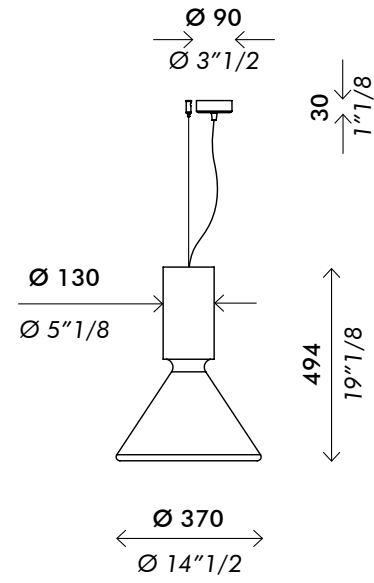

pin S370

pin S160.3



mm/inch

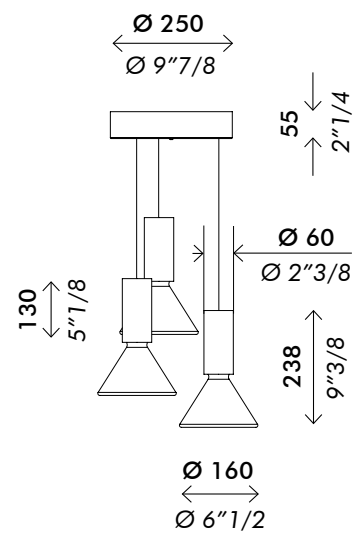

pin S160.3

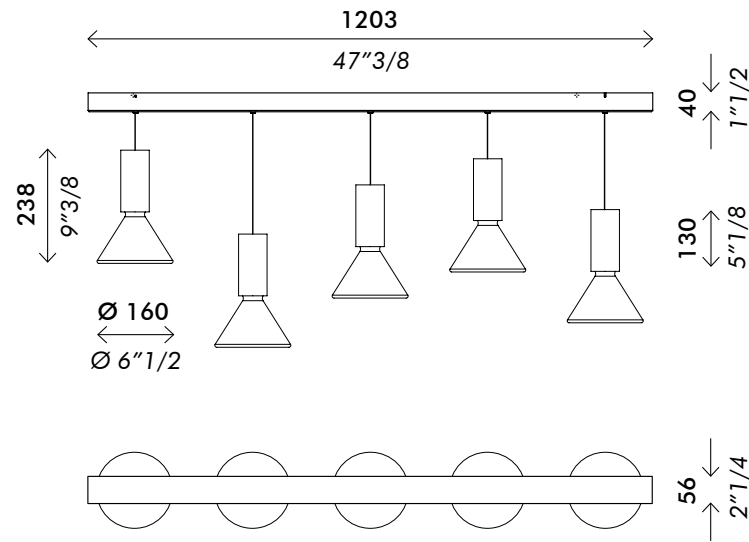

pin S160.5



pin C370



mm/inch

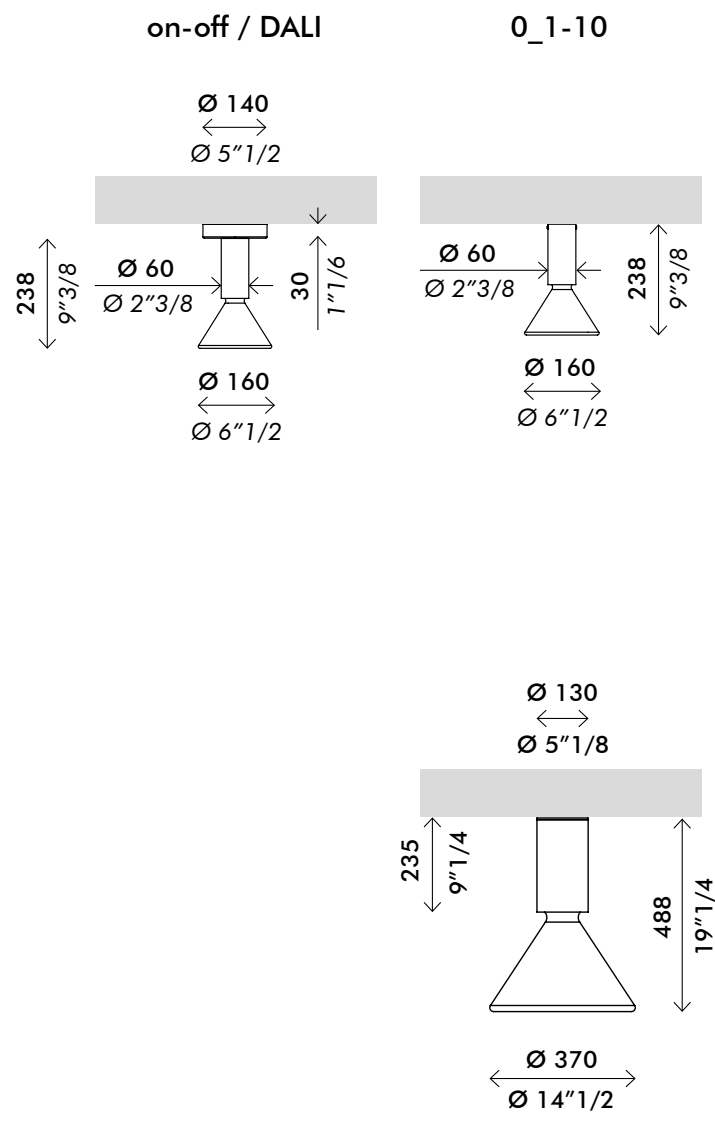

pin C160

pin C370



pin W160



mm/inch

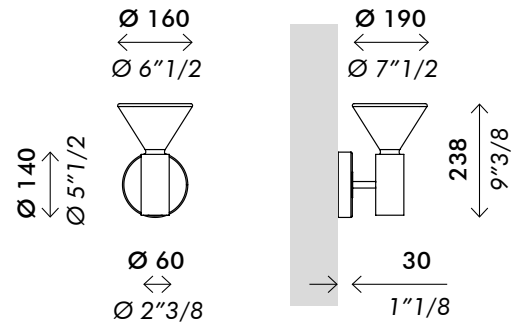

pin W160

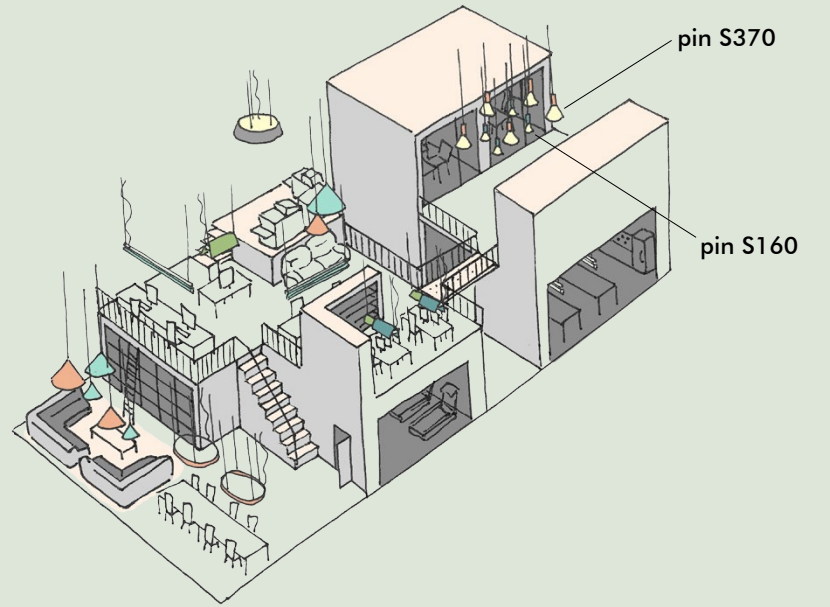



COLLECTION

**pop**

**ANDCOSTA**

# pop

**Hanging lamp with direct light.  
Spun aluminium structure matt  
white, black or brass coated outside  
and matt white coated inside.  
Brass cylindrical detail.  
Metal ceiling canopy matt white,  
black or brass coated  
and black fabric cable.  
LED bulb.**

Smooth and bold  
surfaces which suggest  
colour exercises.

**DESIGN AndCosta R&D — 2018**



discover POP on our website 





pop S400

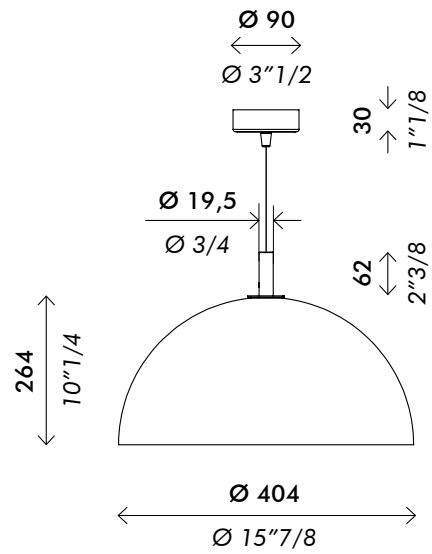

mm/inch



COLLECTION

---

**riga**

**ANDCOSTA**

# riga

**Wall lamp with indirect light.  
Aluminium structure matt white,  
black or brass coated.  
Opal polycarbonate or transparent  
prismatic PMMA diffuser.  
LED module.**

An essential graphic  
interpretation  
of the theme of light  
that embraces surfaces  
highlighting materials  
and finishes.

**DESIGN AndCosta R&D — 2015**





riga W340



riga W340

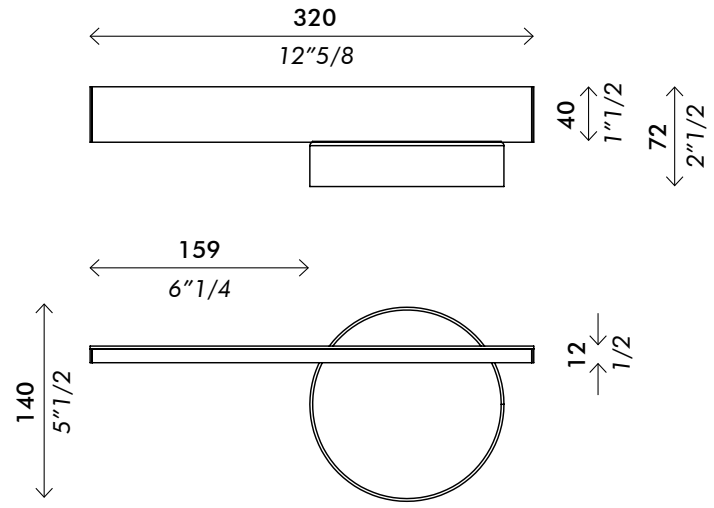

mm/inch



COLLECTION

**steel arc**

**ANDCOSTA**

## steel arc

**Floor lamp with diffused light.  
Polished stainless steel  
adjustable structure  
and brushed stainless steel base.  
White, black or beige 100%  
Polyester 3D fabric lampshade.  
Others available colours on request.  
LED bulb.**

A floor lamp that allows  
a decentralized  
light source.  
The sleek adjustable  
structure comes in  
**polished stainless steel**  
combined with  
**3D fabric** lampshade.



**DESIGN Carlo Zerbaro \_\_\_\_\_ 2003**







mm/inch

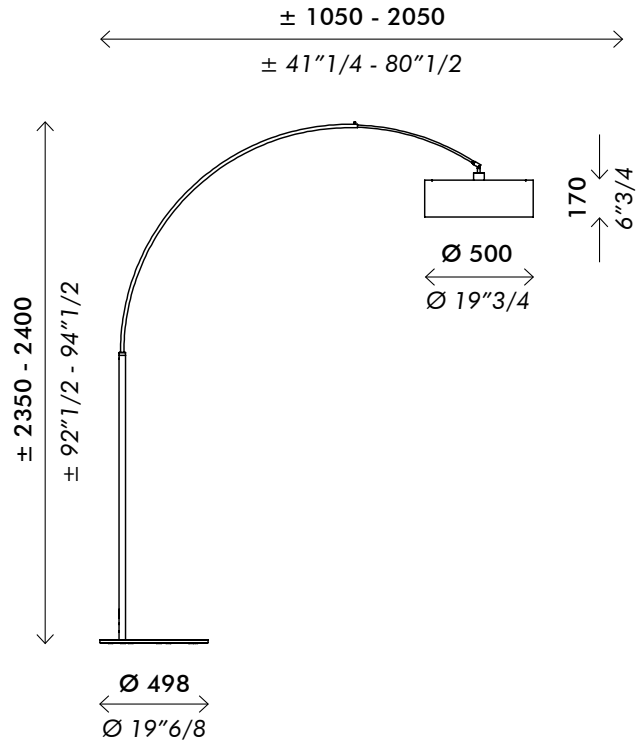

steel arc F2400

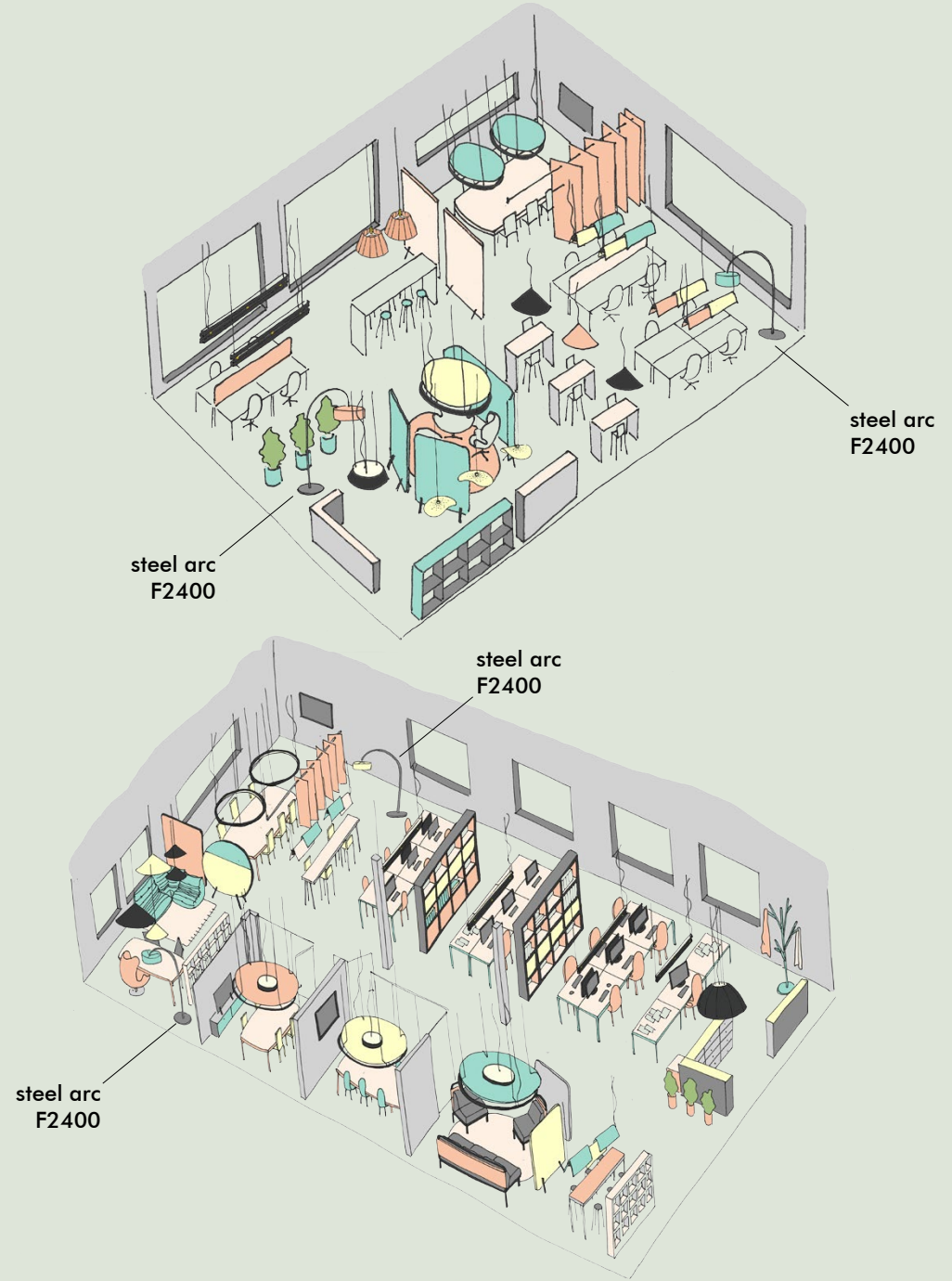
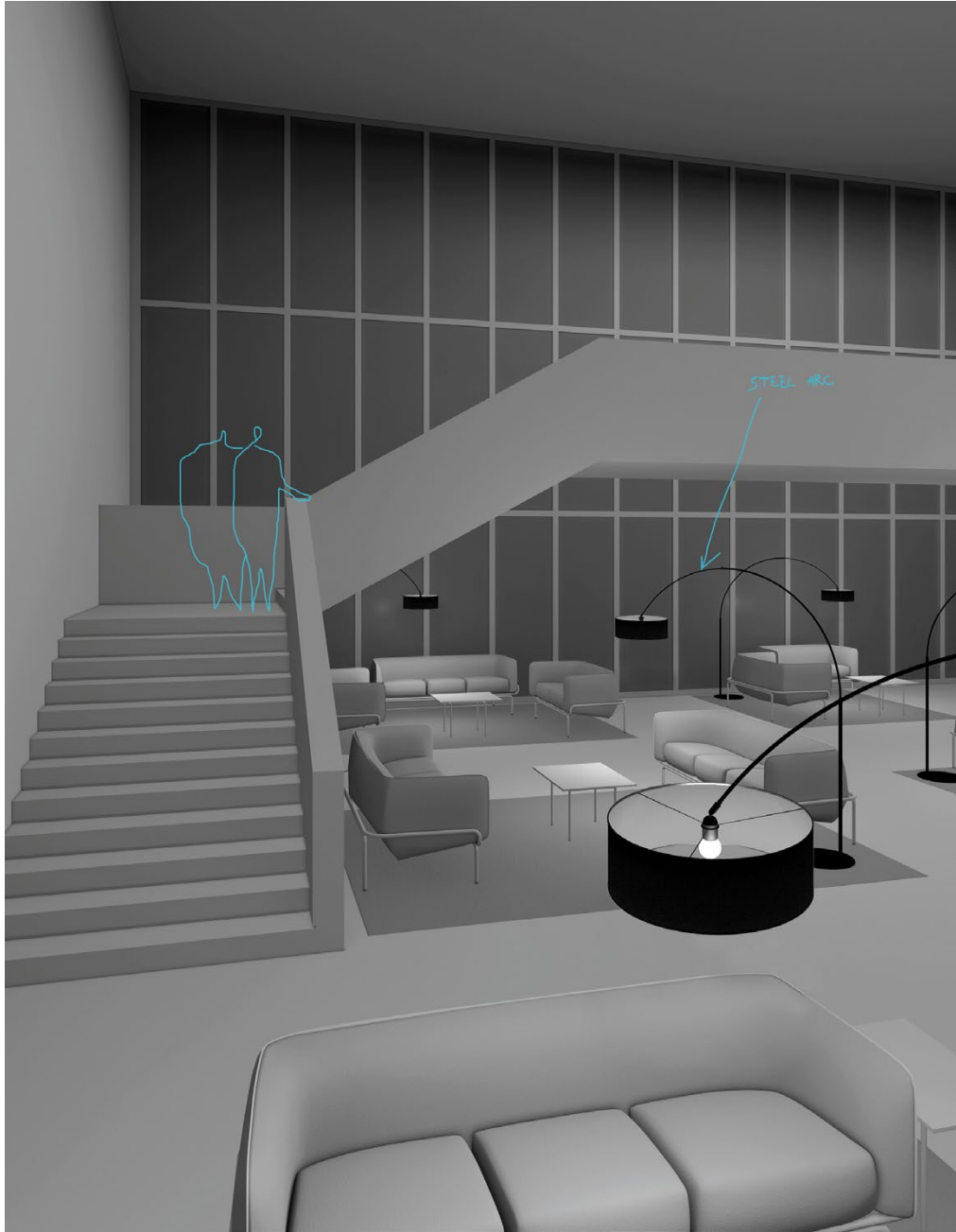

COLLECTION \_\_\_\_\_

**tessa**

**ANDCOSTA**



# tessa

**Hanging lamp with direct light.**  
**Steel structure titanium coated.**  
**Ivory, anthracite or grey removable**  
**Pure New Wool lampshade.**  
**Others colours or finish on request.**  
**Metal ceiling canopy matt black coated**  
**and black fabric cable.**  
**LED module with opal polycarbonate**  
**diffuser. Also available with**  
**LED bulb without diffuser.**

Like bones wear skin  
that smooths their  
edges creating a uniform  
tridimensional texture,  
the warm and soft  
lampshade of **tessa**  
covers an inner steel  
structure producing  
an interesting contrast  
between materials  
and colours.  
Available in two sizes,  
**S640** and **S840,**  
this lamp has a completely  
customizable lampshade  
and structure for a wide  
range of configurations.

**AndCosta R&D** ——— **2019**



**discover TESSA on our website**













tessa S840

tessa S640

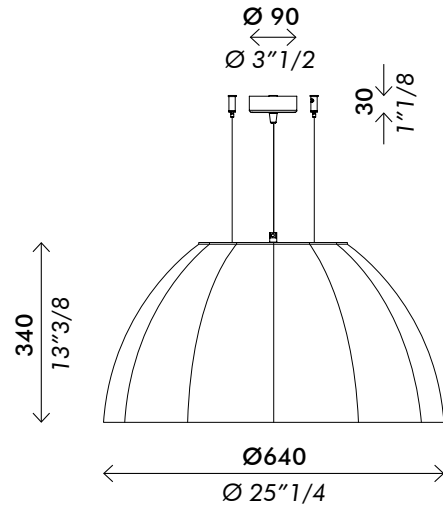

mm/inch

tessa S840

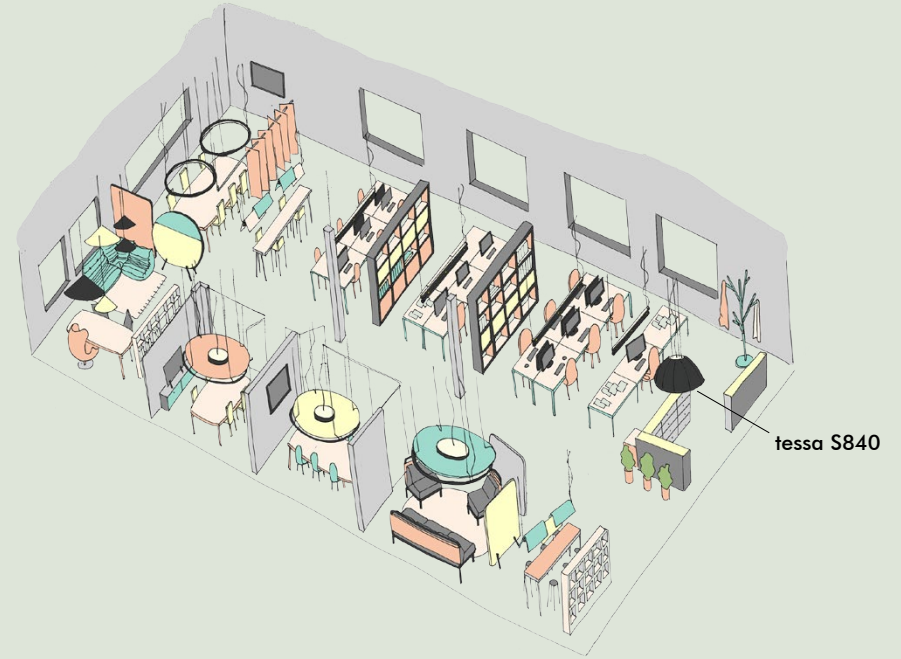
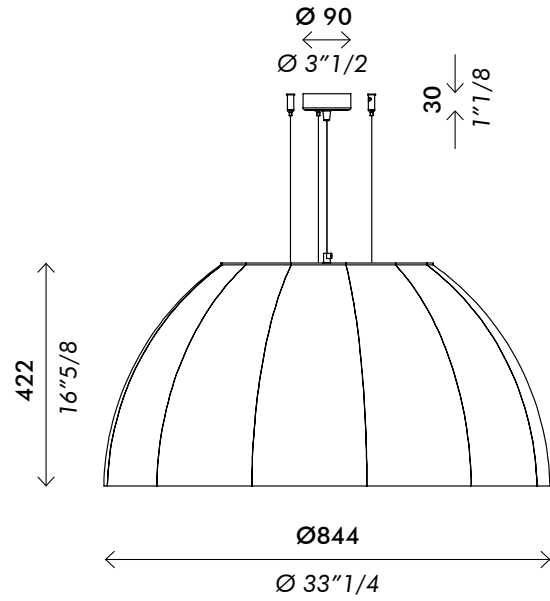

tessa S840



tessa S640

FAMILY \_\_\_\_\_

**tre**

**ANDCOSTA**



**tre**

**Table and floor lamps  
with diffused light.  
Canaletto solid walnut  
wood structure.  
100% cotton fabric lampshade  
black or ivory outside  
and white inside.  
Others colours or finish on request.  
LED bulb.**

Wood and fabric in  
a sleek design that  
conceptualizing the  
shape of nature.  
Tre proposes a fabric  
diffuser on a triple  
handcrafted canaletto  
walnut stem.  
Available both in table  
and floor version:  
**tre T670** and  
**tre F1700.**

**Alessio Bassan** ——— **2014**



**discover TRE on our website** 



tre F1700



tre T670





tre T670

tre T670

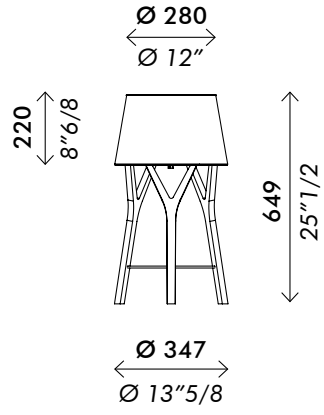

mm/inch

tre F1700

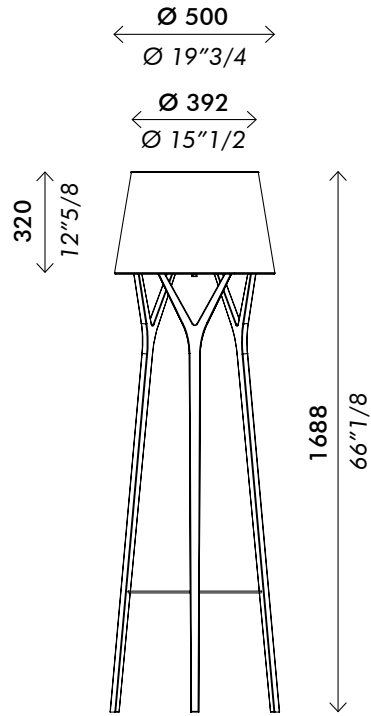

COLLECTION

**turn**

**ANDCOSTA**

# turn

Wall lamp with adjustable  
direct light.  
Aluminium structure matt white,  
black or brass coated.  
Opal polycarbonate or transparent  
prismatic diffuser.  
LED module.

Turn features minimal  
but effective LED  
elements, which can be  
rotated to freely  
change from **direct**  
**to an indirect light**  
response.

DESIGN AndCosta R&D — 2015



discover **TURN** on our website 





**turn W100**

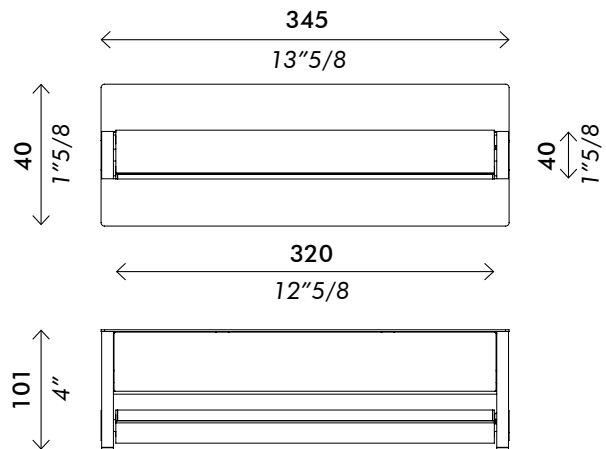

mm/inch



COLLECTION \_\_\_\_\_

**vento**

**ANDCOSTA**

# vento

**Hanging and floor lamps  
with direct light.**

**Hanging lamp with spun aluminium  
lampshade matt white, black  
or brass coated with brass detail.**

**Floor lamp with rotatable and  
extensible steel structure matt white,  
black, brass or titanium coated.**

**Marble top in Marquina Black or  
Carrara White matt finish.**

**LED bulb.**

Honest and clean  
shapes, both hanged  
and pendant from  
an arched structure.

**Vento S500** available  
in matt white, black  
and brass finish and

**Vento F2004** available  
in matt white, black  
or titanium finish.



**DESIGN Carlo Zerbaro ——— 2016-2020**

**discover VENTO on our website** 









vento S480



**vento F2004**

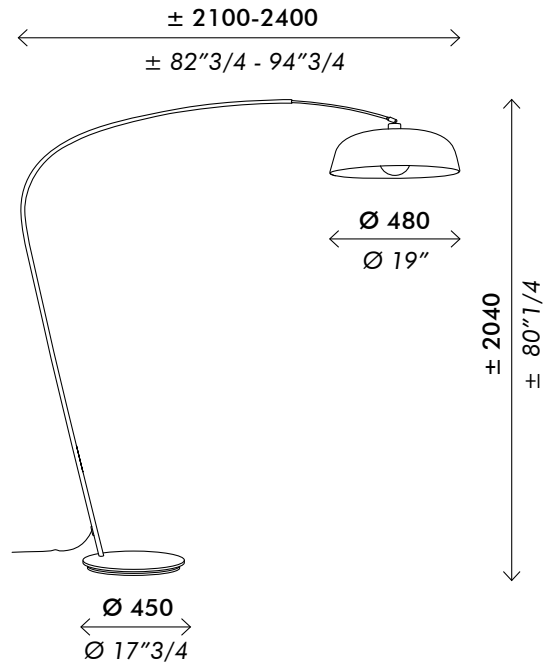

**vento S480**

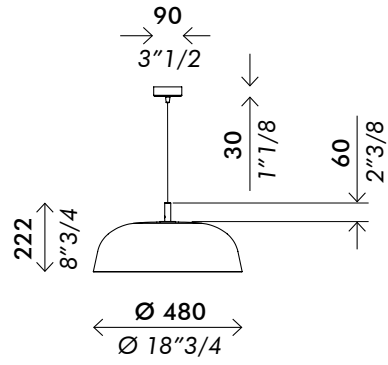

mm/inch

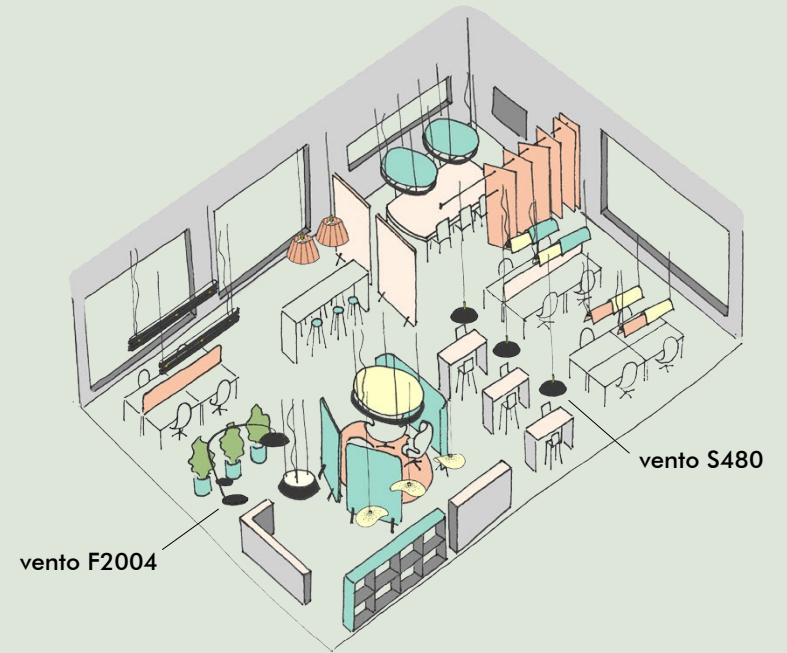

COLLECTION \_\_\_\_\_

**you**

**ANDCOSTA**

# you

**Wall lamp with direct and indirect light.**  
**Aluminium structure matt white or black coated outside and matt white, black or brass coated inside.**  
**Also available gold, silver or copper leaf finish inside.**  
**LED module.**

Inspired by the minimalist purity of Donald Judd, **you** is a collection of wall lamps with integrated LED module.  
Available in three sizes with increasing length and the same depth:  
**you W320, you W480 and you W640.**

**DESIGN Silvio Longhin — 2015**



discover YOU on our website 







mm/inch

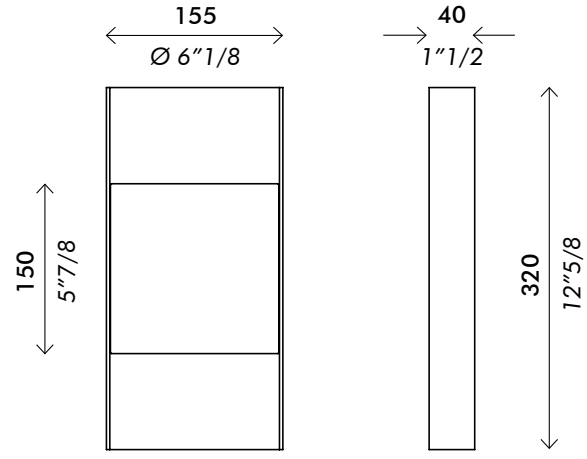



mm/inch

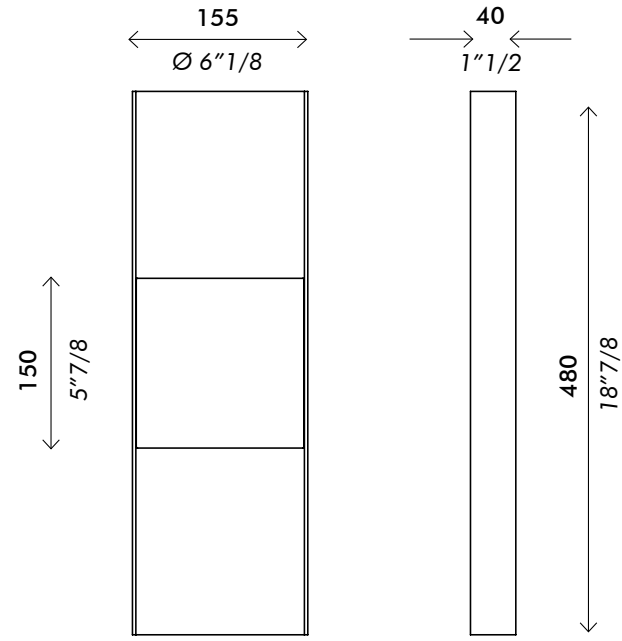



mm/inch

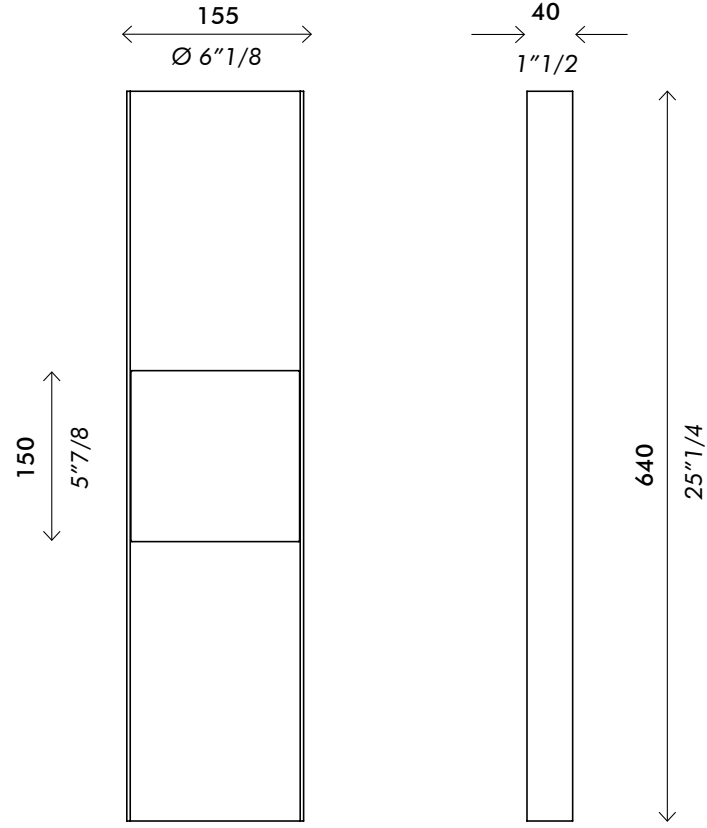

you W640



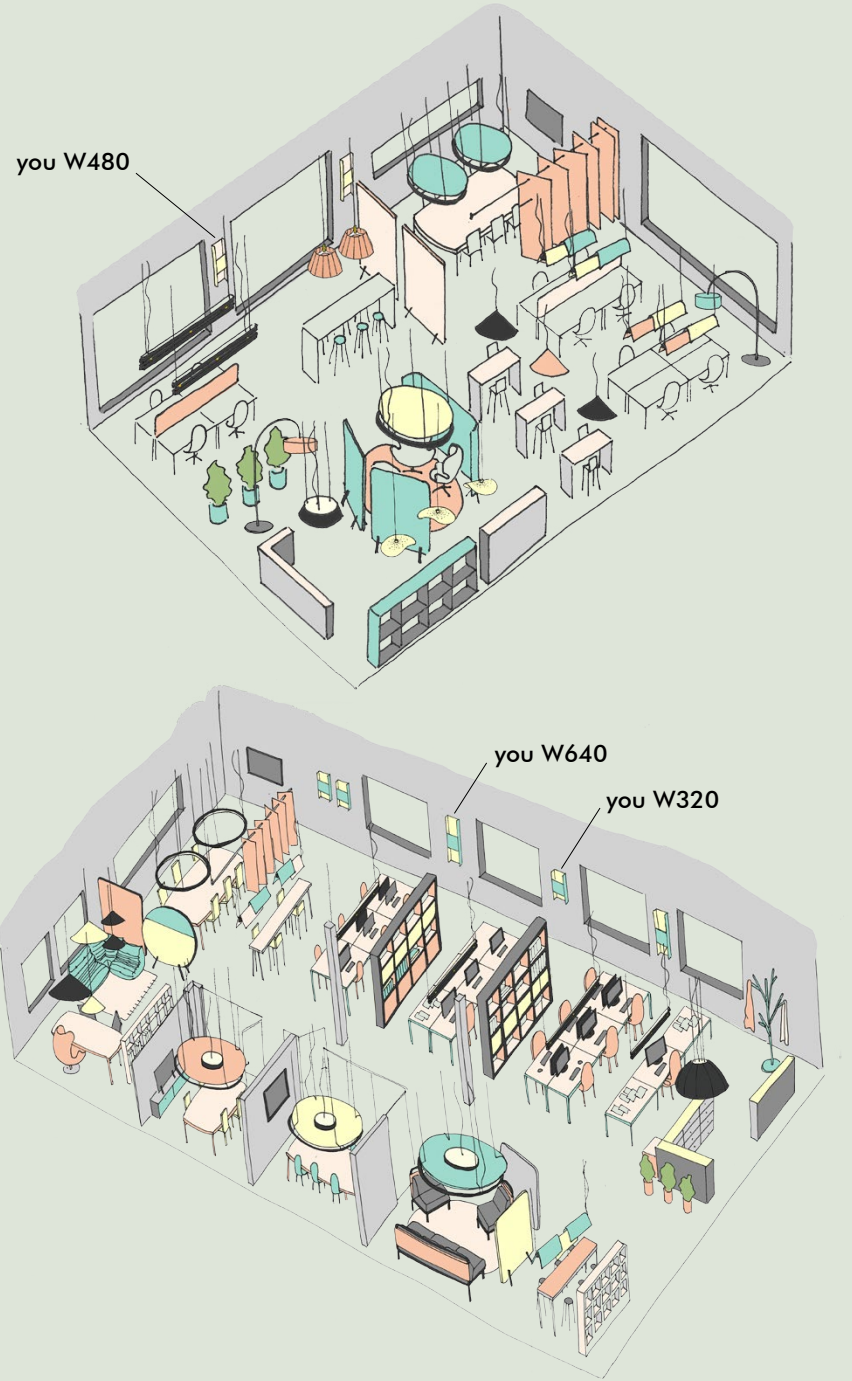
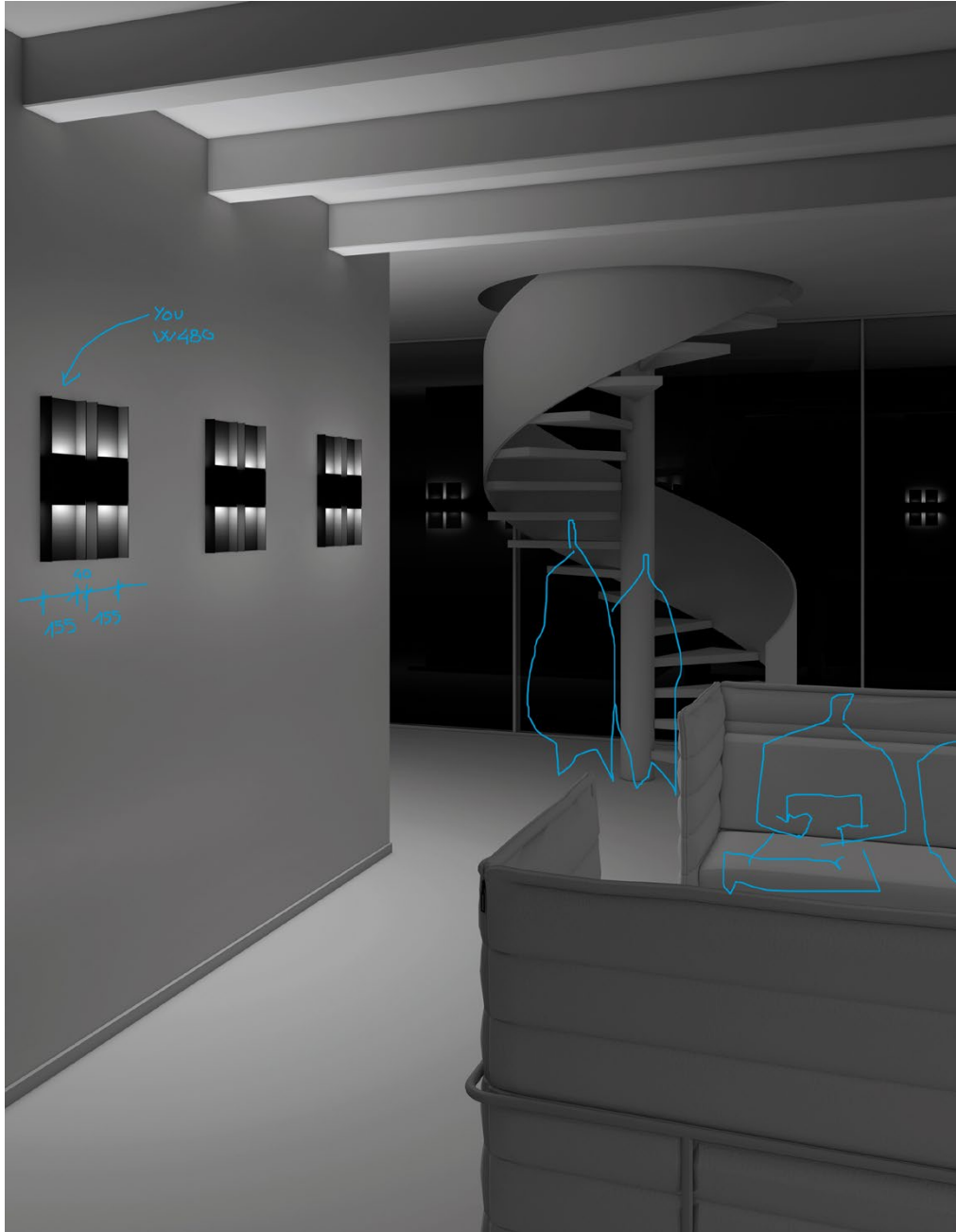

## LIGHTING DESIGN MADE IN ITALY

**Andcosta** is based near Venice, an area that loves design and culture, past and present, craftsmanship and beauty. The company Andcosta is a space for research and planning of lighting design. Rooted in the traditions of Italian design, it creates lighting objects that reflect functionality and timeless beauty in their style.

The company is located inside the walls of the **historical textile mill** of Thiene's town – an evocative place surrounded by the Venetian Prealps and home to the renaissance architect **Andrea Palladio**, the space is rich in culture and artisanal craft traditions, where the past and present represent the birth of the **Italian manufacturing industry**.

The restoration of this mill building, with its **industrial archeology**, has preserved its existing structure, enhancing and adapting its spaces to the requirements of our company.

The industrial architecture was skillfully restored and renovated and its **4000 sq metres of floorspace** now hosts the company's administration offices, the graphics and design team, production and logistics, a photo studio, showrooms as well as meeting and collaboration space. In a place where once textile products were made, now ideas and lighting objects are designed.

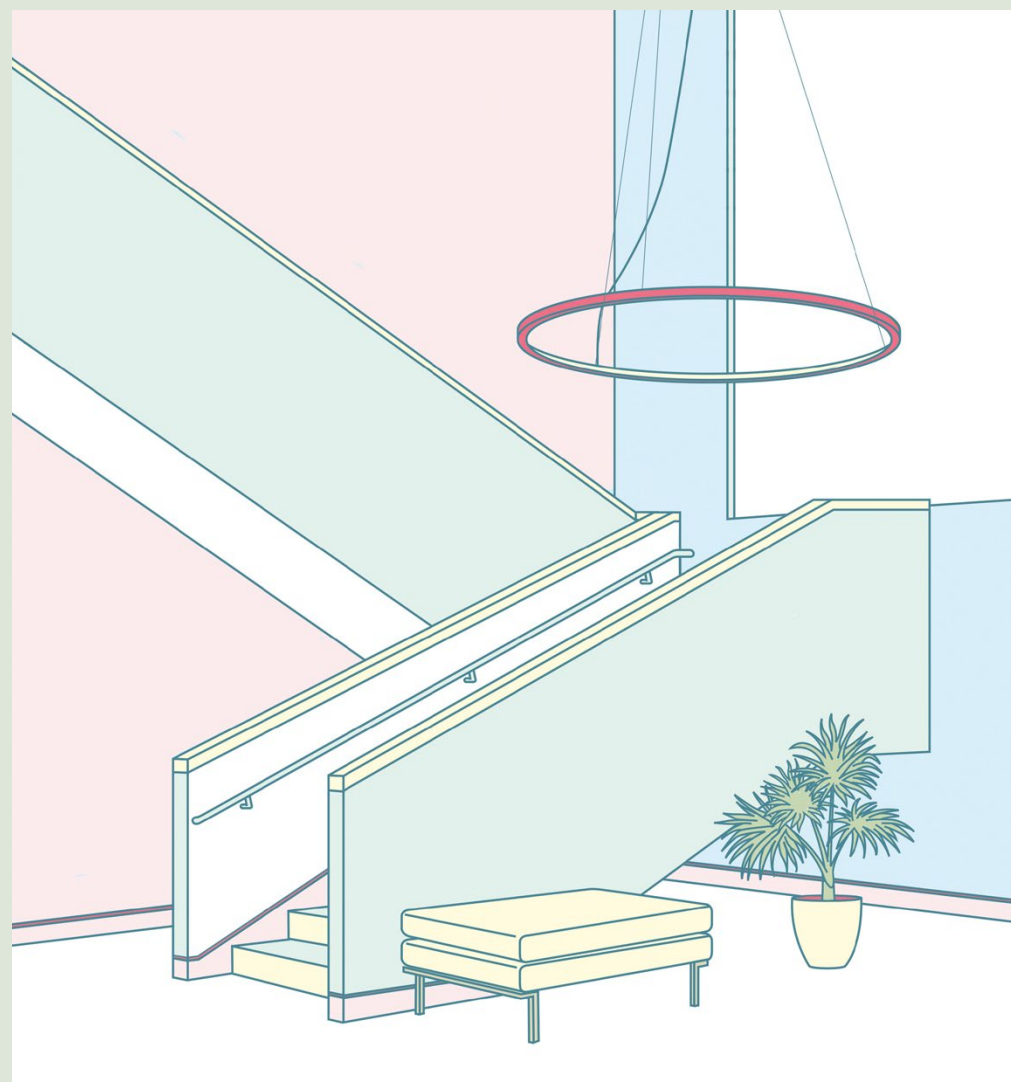

## hanging lamps

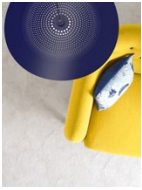

armando



b-pro



circus



daytona



cone



duplo



flat

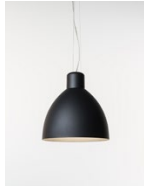

klokke



luna



monocolo



nova



peak

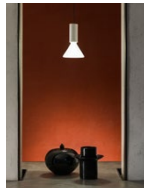

pin



pop



ritmo



fessa



vento

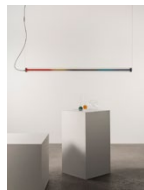

vitreo



volare

## table lamps

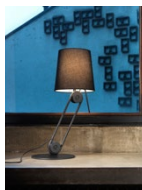

mecano



pin



tre

## ceiling lamps



cyl



daytona

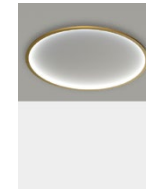

luna



monocolo



nova



pin



ritmo

## floor lamps



grue



luna



mecano

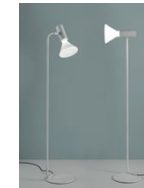

pin



steel arc



tre



vento



vitreo

## wall lamps



cyl



pin



riga



ritmo



turn



you

All rights reserved.  
No part of this publication  
may be reproduced, stored  
in a retrieval system  
or transmitted, in any form  
or by any means, electronic,  
mechanical, photocopying,  
recording or otherwise,  
without the prior permission  
of Andcosta.  
Andcosta reserves the right to  
introduce any changes  
to its own model, without  
prior notice.

Graphic design: AndCosta  
March 2023

© AndCosta. All rights reserved.

AndCosta s.r.l  
via delle Pastorelle 6  
36016 Thiene (VI) - ITALY  
+39 0445 873517  
info@ecosta.it  
andcosta.com





ANDCOSTA